

*A 60-kW Microturbine  
Demonstration Facility.  
Phase II: Instrumentation, Website  
Development, and Evaluation*

*Michael Swedish, Glenn Wrate, Frederik Betz  
Emily Blakemore, Lee Greguske, and Joe Jacobsen  
Milwaukee School of Engineering*

ABSTRACT

The second phase of a joint project between the Milwaukee School of Engineering, the City of Milwaukee, and Wisconsin's Focus on Energy to develop a 60-kW microturbine demonstration facility is described. In Phase I, the facility was designed, constructed, and commissioned. A multidisciplinary team of students and faculty (mechanical and electrical engineering) continues work on the project in this second phase. Coordination among the various stakeholders is crucial to the success of the project. Instrumentation has been acquired, installed, and calibrated. A grid connection agreement with the local utility has been achieved. Milwaukee School of Engineering personnel interface with City of Milwaukee engineers concerning dispatch of the unit. During the heating season, the unit has been dispatched on thermal demand, and the economics of this mode of dispatch have been evaluated. Website development has continued; all instrument readings are accessible on the website, and equations necessary for a First and Second Law analysis have been proofed and placed on the website. Use of the facility as an off-site laboratory for the Milwaukee School of Engineering has begun. An important aspect of this second phase has been the handoff of the project from one team of students to the next. Information transfer has been smooth, and continuity has been maintained. The experiences of the students in working through this phase of the project are described.

## INTRODUCTION

The Microturbine Demonstration Project is a collaboration among the Milwaukee School of Engineering, the City of Milwaukee, and Wisconsin's Focus on Energy. The City of Milwaukee was planning the renovation of a city-owned building into a small office complex. City engineers hoped to incorporate cutting-edge energy technology into the building redesign. Their choice was installation of a 60-kW microturbine manufactured by Capstone, along with a heat recovery unit. The City approached Wisconsin's Focus on Energy, a partnership of private and public organizations focused on energy savings and economic benefit to the State of Wisconsin, as a partial funding source for the project. The Milwaukee School of Engineering was brought into the process to provide technical expertise and to manage an educational component to the project.

A key element of the project plan was the development of a website to monitor the performance of the microturbine in real time, and to provide tracking information on its performance over time. This website would be integrated into the existing local area network of the City. It would also be made accessible from the internet, so that the unit could be monitored from any remote location. For this website to provide useful information, it was recognized from the outset that the facility would need to be extensively instrumented.

For the Milwaukee School of Engineering, the project provided the opportunity to involve students in its development from the outset. A team of two faculty members and three students began work before the foundation slab for the microturbine was poured, and have been involved in all aspects of the project.

Phase I of the project consisted of design, construction, and commissioning of the facility. After choosing a location for the unit, it was necessary to design electrical, mechanical, and control interfaces with existing building systems. The electrical interface allows electrical power from the microturbine's generator to supply a large portion of the building's electrical demand. This interface also includes a parallel connection to the electrical grid, but this grid connection is not intended to allow power from the microturbine's generator to feed the grid. The mechanical interface consists of a hot water supply from the microturbine's heat recovery heat exchanger connected in parallel to two existing gas-fired hot water boilers for supplying thermal energy to the building. The con-

trol interface is two-fold. An electrical interface allows the microturbine to follow the building electrical load. The thermal interface involves a complex interaction between the microturbine's control system and the existing Johnson Controls Metasys HVAC (heating, ventilating, and air-conditioning) system controller for the building.

Construction of the facility was completed in the Spring of 2003, and testing was begun. The unit was commissioned in May of that year.

## TECHNICAL TASKS FOR PHASE II

### **Electrical Tasks**

For the second phase of the microturbine demonstration, several activities were begun and others were completed. The most important of the tasks that was completed during the second phase of the project was passing the interconnection testing with the local utility, WE Energies of Wisconsin. The microturbine and facility completed several tests that now allow the microturbine to run in parallel with the city's utility company. This was a significant step for the microturbine team. Because of the parallel connection, the City of Milwaukee will have the potential to save money through economic dispatch, while at the same time reducing the building's need to fire up the hot water boilers to meet a thermal demand.

An ongoing task of the project is the use of a webcam. The webcam is located in front of the microturbine and is used to record pictures of the microturbine on a two minute interval. The pictures are sent to the project webpage, and the webpage updates every two minutes as the webcam takes a new picture of the microturbine. The files of each picture are also saved onto the server. Every two weeks the space allocated to the project begins to fill up and the files need to be saved to a compact disk for permanent storage. All the files for one day are zipped up into a single file. The new zip files are then copied onto a laptop computer, and the files on the server are deleted to create more room for incoming files. The zip files are then extracted into a folder. Blaze Media Converter software is used to convert the list of \*.jpg files into a \*.mpg movie for the particular day. Approximately two weeks worth of \*.mpg files are saved to a disk and kept in permanent storage. These movie files are used for reliability, availability, and maintainability studies, and also to help troubleshoot any data irregularities.

One of the main electrical duties is to continue to collect data on the Yokogawa power meter data logger. During the first phase of the demonstration project, two of the three hall-effect current sensors were damaged during installation. Since then several options were examined to replace the damaged devices. It was decided that four shunts were to be installed in place of the hall-effect sensors. The shunts are rated 200 amp at 50 mV. Three of the shunts will be used for the 3-phase signal, and the other shunt will be used for the DC signal. All of the shunts are made by Yokogawa so they are compatible with the power meter. Once the shunts were installed and thought to be working properly, the data logger was used to record data. The data can be put into three different formats: numeric, waveform, and numeric and waveform. Data were recorded from the Yokogawa while the microturbine was running at different load levels. For example, files were collected for the microturbine running at approximately 0 kW, 10 kW, 20 kW, 30 kW, 40 kW, 45 kW, 50 kW, 55 kW, and 60 kW.

Two other tasks that have been completed during the second phase of the project are programming of the OPTO 22 data logger and the PMII power monitor. The original OPTO 22 was replaced by an upgraded model. The set-points for the upgraded model, called the Ultimate Brain, needed to be reprogrammed. These set-points inform the OPTO of the lower and upper limits for each sensor or transducer that is wired to it. Once the set-points were programmed, the OPTO was able to send the correct data to the Engage website for viewing and trending. The PMII also needed programming. The PMII monitors the power quantity of the energy supplied from the microturbine. The PMII needed to be programmed to send an alarm if the IEEE 519 Standard is violated in any way. The alarm is sent to the Engage website, and emails are dispatched to certain people working on the project.

#### **Mechanical Tasks: Instrumentation**

Several types of transducers are used to analyze the thermodynamic states of the microturbine cogeneration system. These transducers include thermocouples, pressure gauges, flow meters, accelerometers, and acoustical meters.

The thermocouples measure the following temperature points:

- Ambient
- Air compressor outlet
- Turbine exhaust

- Microturbine unit exhaust
- Heat exchanger inlet (water and air)
- Heat exchanger outlet (water and air)
- Gas compressor inlet
- Gas compressor outlet.

The pressure transducers measure the following pressure points:

- Ambient
- Microturbine unit exhaust
- Heat exchanger inlet (water)
- Heat exchanger outlet (water)
- Gas compressor inlet
- Gas compressor outlet.

The flow meters measure the following flow rates:

- Exhaust gas flow
- Natural gas flow
- Water flow.

Utilizing these sensors along with an experiment to determine the exhaust properties of the air, a complete set of thermodynamic equations was developed for the first and second laws.

Two major concerns for the installation of a microturbine are reliability and maintainability. To monitor the microturbine, an accelerometer was installed to record the vibrations emanating from the shaft. The data from the accelerometer will be used to determine a maintenance schedule for the microturbine, and record any warnings that a catastrophic failure may be imminent. An acoustical meter will monitor the sound coming from the microturbine, which will also be useful in determining a maintenance schedule as well as analyzing possible failures.

The data from the sensors are routed through a data acquisition system and transmitted to the web via software and hardware from Engage Networks. The data can be remotely accessed from any PC through [www.elutions.com/aem](http://www.elutions.com/aem). Utilizing this software and equations developed to analyze the plant, real time first and second law efficiency can be observed.

### **Mechanical Tasks: Thermodynamic Modeling**

One of the priorities for the project was to provide a complete First and Second Law thermodynamic analysis of the microturbine

and associated equipment utilizing data from the operation of the unit, and to make the results accessible from the website. To this end, each component of the unit was modeled separately, and then a model was created for the unit as a whole. The model was developed in such a way that the inputs to the model were actual data points recorded by the instrumentation. The equations were then inserted into the website. The model is capable of providing real-time information on energy and exergy transports and exergy destruction for each component, and for the unit as a whole.

A line drawing of the microturbine/heat recovery system as installed is illustrated in Figure 1. A sample of results for the Microturbine and Heat Recovery components is shown in Table 1.

### **Economic Modeling**

The goal of this activity is to determine under what conditions the microturbine operation results in cost savings for the building owner, the City of Milwaukee. The cost of microturbine operation must be compared to the purchase of electricity and purchase of natural gas for the building's hot water boilers. Rates for natural gas and electricity will vary with time of year, and may vary with time of day. Development of a model is underway that will take real-time data on building loads and rates for electricity and gas and determine a point at which the microturbine should be dispatched. The model should be capable of displaying the net benefit, or cost, of microturbine operation under different operating scenarios.

### **Website Development**

The website for the Focus on Energy Microturbine Project, [www.msoe.edu/orgs/focus/microturbine](http://www.msoe.edu/orgs/focus/microturbine), provides detailed information on the status of the project as well as data and mathematical models for mechanical and electrical engineering and financial models. The website is broken into nine subpages.

- Home
- Background
- Methodology
- Data
- Multimedia
- Links
- Participants

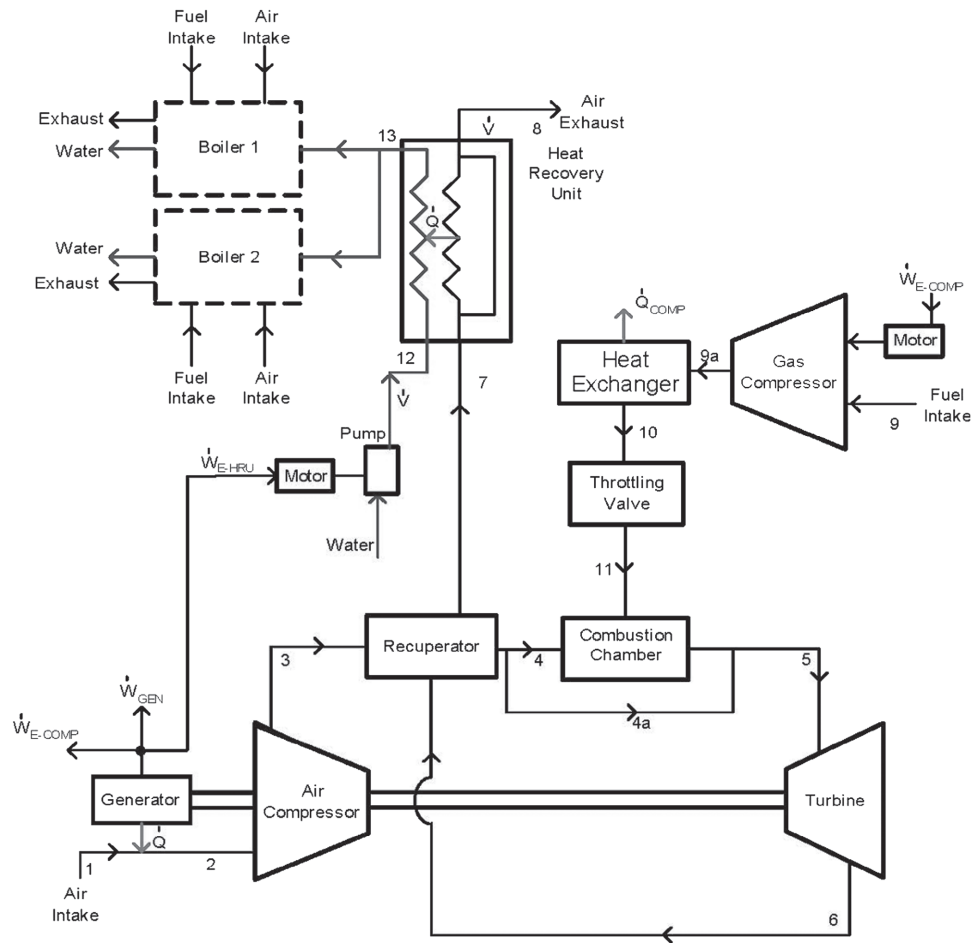

Figure 1. Schematic

- For Business
- For Professors.

The Home and Background pages describe the purpose of the project, which includes a previous American Society for Engineering Education (ASEE) paper from 2003.

The primary engineering portion of this website comes from the methodology section and the data section. The methodology section breaks down each component of the power plant and describes the theory and assumptions used to analyze each component. Furthermore,

Table 1. Transducer Specifications

| Microturbine Transducers |                        |                     |                     |                 |  |  |
|--------------------------|------------------------|---------------------|---------------------|-----------------|--|--|
| <i>Item #</i>            | <i>Type</i>            | <i>Manufacturer</i> | <i>Model #</i>      | <i>Quantity</i> |  |  |
| 1                        | Thermocouple           | Acromag             | 151T-0600/155H-0600 | 7               |  |  |
| 2                        | Pressure Gauge         | Endress + Hauser    | Cerabar M PMC 41    | 5               |  |  |
| 3                        | Exhaust Gas Flow Meter | Sage                |                     | 1               |  |  |
| 4                        | Natural Gas Flow Meter | We Energies         |                     | 1               |  |  |
| 5                        | Water Flow Meter       | Endress + Hauser    | Prowirl 77          | 1               |  |  |
| 6                        | Acoustical Meter       | ICP                 | 130D10              | 1               |  |  |
| 7                        | Accelerometer          | IMI Sensors         | 626A01              | 1               |  |  |

there is a complete plant analysis used to determine the overall efficiency of the power plant on a first and second law basis. The data section provides electrical and thermodynamic data points from the microturbine via Engage Networks' Active Energy Management (AEM) program. These data can be utilized by electrical and mechanical engineers to analyze the plant in real time.

The multimedia page provides a real time look at the microturbine via a webcam. Utilizing this webcam, a selection of images can be recorded, and a time lapse video is created periodically, which provides a visual record of the operation of the microturbine. Furthermore, there is a gallery of images during the construction of the microturbine site. The links section provides further resources on microturbine technology as well as links to corporations that provided hardware for the installation of the microturbine.

The participants' page includes institutions and corporations that have played a key role in the funding and progress of this project.

The For Business section provides a financial model of the microturbine in peak shaving modes as well as thermal dispatch mode. These models can be utilized to determine if microturbine technology is cost effective for a variety of applications.

Finally, to facilitate the dissemination of information to other universities and institutions a page "For Professors" has been created. This page allows individuals to gather information directly from the team of faculty and students at Milwaukee School of Engineering that have been working on this project.

## PROGRESS ON PEDAGOGICAL GOALS

### **Student Involvement**

From the outset of the project, an effort has been made to involve students in all aspects of the design and implementation of the microturbine. Three students, two mechanical and one electrical, coordinated activities for instrumentation and website development in the first year. In the second year, one of these students has carried over, but two new students have been added. The transition from one team to the next has been smooth. Weekly meetings have kept all participants up to date. The student teams have been invaluable in troubleshooting the project. They interface with all of the vendors, as well as the project stakeholders.

The students in the first year of the project were undergraduates. The current year students are enrolled in the Masters in Engineering Program. The students are paid an hourly rate for time spent on the project. Although the work that they are doing is relevant to their graduate programs, to this point they have not received academic credit for their work on the project. They will be responsible for reporting the results of the project upon its completion.

### **Electrical Engineering Goals**

Via the web, electrical engineering courses are now able to view power quality data for the interconnection of the microturbine to the building electrical system (from the Power Monitor II). Power Electronics classes can now view selected current and voltage waveforms for the high-speed ac bus and the dc bus. Power on the high-speed ac and dc bus is also available (all from the Yokogawa power meter). With these data available on-line, this facility is a great supplement to textbooks and computer simulations in the areas of power electronics and power system design and analysis.

Recent world events have made the distributed generation of electricity one of the most important topics in the power system area. While traveling through Ohio, one of the authors experienced firsthand the importance of back-up or auxiliary power generators. The cities along the turnpike were all without power, but the service centers had their own generators. While not as large as those units, this facility offers educators and students a detailed view of the workings of one of the most promising forms of distributed generation: a microturbine with a waste heat recovery system.

The microturbine in this system is equipped to operate in stand-alone mode. Stand-alone mode allows power generation when no power is available from the electric utility. In other words, the system will be capable of generating power in the case of a power outage. A large on-board battery pack is used to power connected loads and start the microturbine. Once the microturbine reaches full speed, the large battery pack is utilized as an electric buffer. In addition to start-up, the battery provides extra power in the case of a sudden load increase, and therefore allows the microturbine time to increase speed to meet the load demand. This battery will also sink power in the case of a sudden load decrease. The stand-alone mode feature of the microturbine should not be confused with an uninterruptible power supply (UPS). The system

will only be capable of running small and important building loads, such as lighting. Unlike a UPS, in the case of a power outage, the system will require startup time before it is capable of providing power.

### **Mechanical Engineering Goals**

It is now possible to access results of the thermodynamic analysis of the microturbine installation remotely from the web. These data can be used in the undergraduate Thermodynamics classes to illustrate the application of Second Law principles to a real installation. Inefficiencies in the system can be pinpointed, and brainstorming sessions on steps to improve efficiencies can be conducted. Comparisons to other methods of electrical and thermal energy generation can be made.

The installation site, located 5 miles from the Milwaukee School of Engineering campus, has become an "off-site laboratory." With the cooperation of the City of Milwaukee, teams of students have traveled to the site to inspect the installation. These site visits, along with access to the website, have been met with enthusiasm by the students.

## PROGRESS ON GOVERNMENT/INDUSTRY GOALS

### **Demonstration of Technology**

The microturbine has now been available for operation through a summer and a winter season. Some lessons already have been learned. Dispatch of the unit on electrical demand has been straightforward. However, dispatch on thermal demand during winter months presented a problem. The heat recovery heat exchanger was designed to bypass exhaust gas flow to match the thermal load. However, when control of the unit was attempted through the Metasys building system, it was found that the microturbine itself cycled on and off frequently in response to the Metasys signal. This problem was addressed through adjusting the hot water set-points for the Metasys system.

To achieve the parallel operation agreement with the local utility (WE Energies), it was necessary to pass startup and power quality tests. The unit was initially unable to pass these tests, but after upgrades to some of the equipment, the tests were passed. This agreement provides only for parallel operation, and does not allow for sending energy from the microturbine back into the grid. Because the occupied building electrical demand exceeds the microturbine rating, it is felt that this is a satisfactory arrangement.

### **Pilot Test for the City of Milwaukee**

The city of Milwaukee has remained engaged in this demonstration project. City engineers troubleshoot the unit and interface with the Milwaukee School of Engineering team. The potential exists to expand a cogeneration technology to many city-owned buildings. A detailed economic analysis will allow the city to determine whether this microturbine technology is a good fit.

### **Energy Savings**

Some preliminary results are available with respect to possible energy savings with this cogeneration installation. Because of the relatively high cost of natural gas, it is unlikely that the microturbine will be a cost-effective alternative to purchased electricity, unless high peak electric rates are triggered. The true value of the facility comes in its potential to provide thermal energy to the building. For this reason, it is advantageous to add as much thermal load to the unit as possible. One major limitation to this installation is the lack of thermal load in the summer. Summer thermal load could be provided by an absorption refrigeration system for building cooling. Unfortunately, this building has an existing vapor-compression refrigeration system. It is, however, possible to perform an economic analysis that would uncover energy savings that might occur were absorption refrigeration to be included. An important lesson here is that decisions about the feasibility of a cogeneration installation should not be made without including heating and cooling systems for the building in the analysis.

### **PROGRESS ON PUBLIC GOALS**

Early in the development of the project it was recognized that a public audience could benefit from an understanding of distributed generation. Part of this public audience consists of developers and building owners, a segment specifically targeted by Focus on Energy as having the potential to employ energy-saving technologies. For this group, the physical site of the microturbine, as well as the website, provide tools for education. Site tours and presentations are anticipated for this group. For the general public, the publicity generated by the installation has been of value. Because the facility is operated by the City of Milwaukee, city taxpayers are actually stakeholders in

the project. This has helped to generate media attention.

#### CONCLUSIONS/FUTURE WORK

As the second phase of the project concludes, work moves forward on creation of a price model for dispatch of the microturbine. The results of the thermodynamic model need to be evaluated. As the unit continues to run, experience with its operating characteristics is being gained. Website development is not yet complete, and will continue. Once a second year of operation has been accomplished, a comprehensive report on the project will be prepared.

#### ACKNOWLEDGMENTS

The authors offer their sincere thanks to Venu Gupta, director of building and fleet services; Joseph Jacobsen, management facilities engineer; and Andrew Hilgendorf, electrical services supervisor of the City of Milwaukee Department of Public Works; Dave Broihan at Unison Solutions LLC, and Alan Gilgenbach, director of internet application technology at Engage Networks, Inc., for their ongoing work on this project.

#### **Bibliography**

- Glenn Wrate, Michael Swedish, Frederik Betz, Justin Reese, Chad Weis, and Lee Greguske, "Design, Construction, and Commissioning of a 60-kW Microturbine Demonstration Facility," Proceedings of the 2003 American Society for Engineering Education Annual Conference and Exposition, Washington DC.
- Ngo Dinh Thinh, Andrew Banta, "A Student Designed Instructional Cogeneration Laboratory," Proceedings of the 1996 American Society for Engineering Education Annual Conference and Exposition, Session 2633, Washington DC.
- Glenn Wrate, "Focus on Energy – Wisconsin's Initiative to Reduce Industrial Energy Consumption," Proceedings of the 2002 American Society for Engineering Education Annual Conference and Exposition, Session 2333, Washington DC.
- "Water tower getting new life with offices, microturbines," Milwau-

kee Journal Sentinel, December 22, 2002.  
Yokogawa Electric Corporation, WT1600 digital power meter, [www.yokogawa.com/tm/Bu/WT1600](http://www.yokogawa.com/tm/Bu/WT1600).  
Allen-Bradley, Rockwell Automation, [www.ab.com/PEMS/products.html](http://www.ab.com/PEMS/products.html).

---

#### ABOUT THE AUTHORS

**Michael Swedish** is a co-principal investigator for this project at the Milwaukee School of Engineering. Professor Swedish is an associate professor and chair of the energy committee in the Mechanical Engineering Department. He graduated in 1979 with a Master's degree in mechanical engineering from Marquette University. He is a licensed Professional Engineer in the State of Wisconsin.

**Glenn Wrate, Ph.D.**, is a co-principal investigator for this project at the Milwaukee School of Engineering. Dr. Wrate is an associate professor and the director of the Master of Science in Engineering Program. He graduated with a Doctor of Philosophy in electrical engineering from the Michigan Technological University in 1996. His Professional Engineer license is registered in the State of California.

**Frederick Betz** is an assistant graduate researcher on the project. He is a graduate student at the Milwaukee School of Engineering. He graduated with a Bachelor of Science in mechanical engineering from the Milwaukee School of Engineering in 2003.

**Emily Blakemore** is an assistant graduate researcher on the project. She is currently working on her Master of Science degree in electrical engineering at the Milwaukee School of Engineering. Emily graduated in 1999 from Indiana University with a Bachelor of Science degree in mathematics.

**Lee Greguske** is past manager of technology for Focus on Energy and contract administrator for the project.

**Joe Jacobsen** is a facilities management O&M manager for the city of Milwaukee, with 20 years experience in plant operations and management. He teaches statistics and mathematics and his research interests are the diffusion of innovations from science to the marketplace, planned performance modeling and nonlinear dynamics applied to a variety of disciplines. He is currently a doctoral candidate at Marquette University.