

Combined Photovoltaic and Thermal Power System Improves Cost Effectiveness

*Dr. Robert R. Walters
ENTECH, Inc.*

ABSTRACT

This article reviews state-of-the-art photovoltaic hardware that can provide combined heat and power (CHP). The improved economics of using photovoltaic (PV) power systems with CHP capability over conventional PV systems is discussed along with the improved market penetration potential in a variety of distributed generation applications. The key issues are summarized that need to be considered to determine project cost effectiveness including applications that will benefit most from the PV system's dual energy output, effect of geographic location on system performance, and available federal, state and local financial incentives.

INTRODUCTION

Many of the technical, economical and social advantages of distributed generation, that is generation located at or near the point of use, are well known [1, 2] and will not be elaborated on here. The additional advantages of using CHP systems in distributed generation applications [3, 4] are particularly attractive, especially for increasing energy efficiency.

Solar systems, particularly solar photovoltaic (PV) systems, are ideal for the distributed generation (DG) environment because they can generally be readily located at or near load centers, or energy users. They are ideally suited especially because they are environmentally friendly, as a result of their quiet, non-polluting performance, and because they are a reliable and secure power source. President Bush even mentioned

in his letter to the 26th World Energy Engineering Congress (WEEC) last year [5] that he was calling on Congress to enact laws that would, among other technologies, promote solar power. The U.S. Department of Energy's Distributed Energy program activities are aimed at increasing acceptance of CHP in end-use sectors [3]. It seems logical that use of solar CHP will help increase acceptance because of the advantages listed earlier for solar.

The increasing acceptance of conventional solar PV systems that provide electricity only and an overview of the details of matching those PV systems to users are documented elsewhere [6].

A particular PV technology is available [7] that provides a CHP option so that the attractiveness of PV and CHP can be combined. This technology is described below followed by a discussion of the economic advantages over a PV only power system. This discussion is not aimed at policy regulation or utility interconnection issues related to DG or CHP but mainly the simplicity of using a PV system with a CHP option and the resulting improved economics that provide for more cost effective applications and increased market penetration capability.

PHOTOVOLTAIC CHP TECHNOLOGY

Basic Concentrating Photovoltaic Hardware

ENTECH's basic concentrating PV modules are the world's largest, with an aperture area of 3 square meters aimed at the sun. Each module is 0.9 meters (3 feet) wide, 3.7 meters (12 feet) long, and 0.9 meters (3 feet) high. A long-life, all weather, marine-grade aluminum housing supports the large primary acrylic Fresnel lens in reference to the solar cells and provides an environmental enclosure. The Company's passively cooled module design keeps the solar cells about as cool as those in "flat plate" PV modules because it has twice the cooling area of a conventional flat plate PV module. ENTECH has several patented technologies in the design and assembly of the module, which significantly increase its performance and reliability while reducing its cost.

This silicon-cell based PV module is rated at 430 watts (detailed specifications are provided on the web site [7]). This is a fully-developed and commercially ready module design that has been used in many previous projects. This PV module, shown in Figure 1, uses large acrylic plastic Fresnel lens to create a primary line focus of sunlight onto the solar

cell assemblies. Concentrating the sunlight to 20 times its normal intensity reduces the amount of the most expensive component, the silicon cell material, by 95%, compared to conventional “flat plate” PV modules. The uniquely designed PV concentrator cell is a modified version of the crystalline silicon cell used in flat plate PV panels. The major difference is that the grid on the concentrator cell’s surface, used to retrieve the power from the solar cell, conducts over 20 times more electrical current than the same type cell in a flat plate module. Consequently, this cell has a larger conductive grid. A specially designed optical cover is bonded to the top surface of the solar cell to redirect incoming light away from the grid onto the active silicon material on the solar cell. Therefore, the larger, more effective conductive grid does not reflect or block any sunlight from reaching active solar cell material. Each module has 37 solar cells electrically connected together like the positive and negative connections of batteries, to provide 17 to 20 volts DC, depending on the ambient temperature. The modules are connected in series to increase the voltage to a desired design level. In large applications the voltage level is increased to 300 volts DC or greater to improve the performance of the DC/AC inverter.

This module is used in both the ENTECH *SunLine*TM and ENTECH *SolarRow*[®] solar arrays. The ENTECH *SunLine*TM (Figure 2), using two of ENTECH’s photovoltaic (PV) modules, provides electricity in any sunny part of the world for small kilowatt power applications, such as remote homes, remote water pumping and other off-grid power needs. The *SolarRow*[®] uses 72 of these same PV modules in a larger tracking frame to meet more substantial power demands such as for commercial, industrial, utility and village applications and is shown in Figure 3.

Combined Photovoltaic & Thermal Module

An option is available with the basic PV system described above that provides both electricity and hot water. For every kWh of electricity generated more than 4 kWh of thermal energy is generated. These unique module options are shown in the Figure 4 below.

The focused sunlight on the solar cells in the ENTECH PV module is shown in Figure 5 along with photos of cross sections of the different module receiver options. This article addresses the application of the PV module with this second receiver option for providing both electricity and heat, or CHP. To maintain a balance between the solar cell performance, which decreases with temperature, versus the cooling fluid temperature, which has more applications as its temperature increases, the fluid

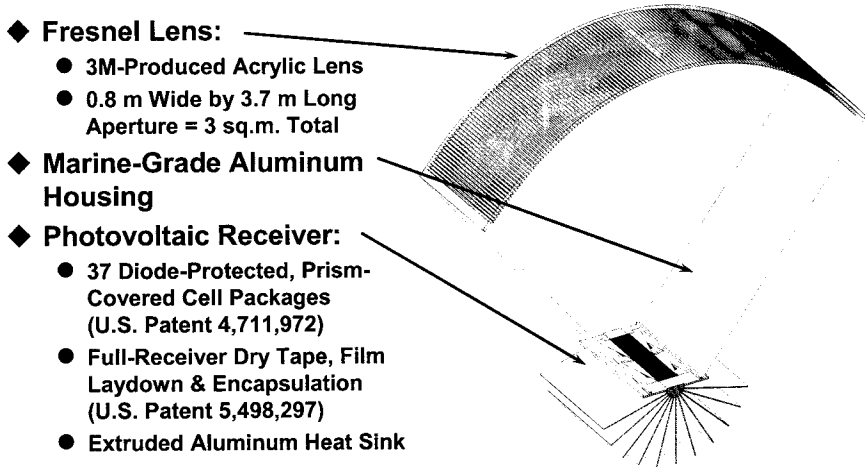

Figure 1. Cross-section of Passively Cooled PV Module

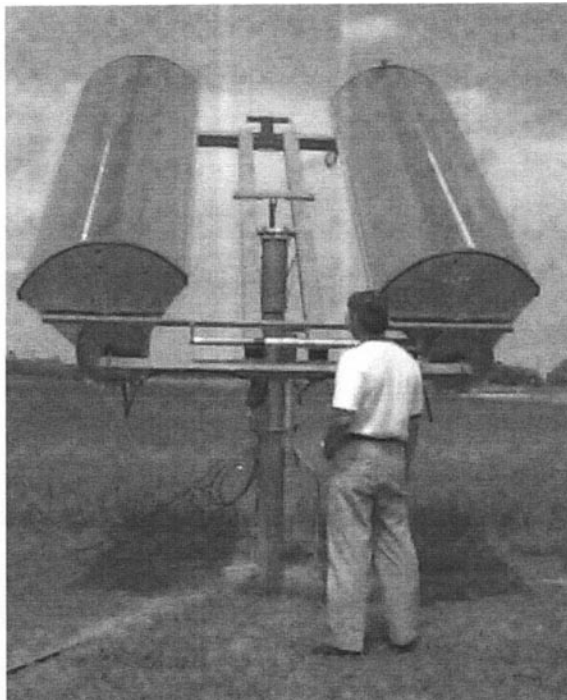

Figure 2. ENTECH SunLine™ Array



Figure 3. ENTECH SolarRow® Array

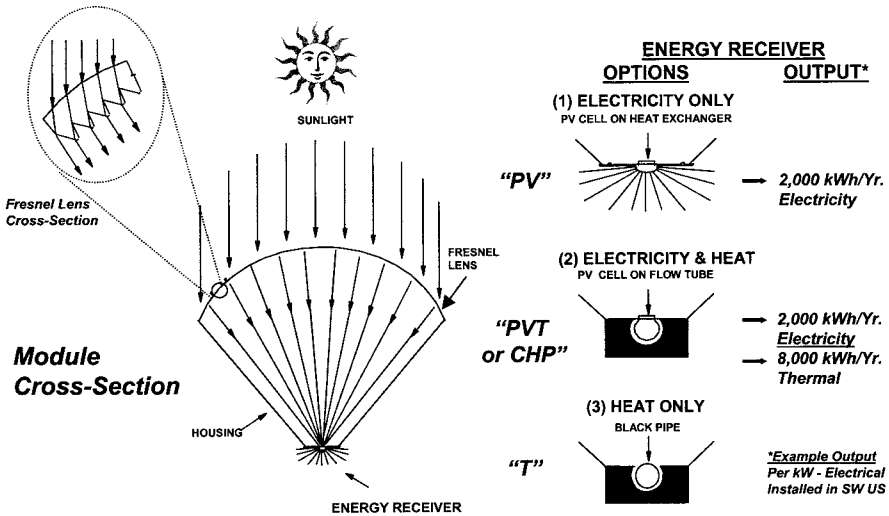

Figure 4. PV Module Receiver Options

temperature is normally maintained below 200°F (93°C). If the heat is only being used for a domestic hot water type application [140°F (60°C)], then the receiver fluid output temperature can be lowered to about 160°F (71°C) allowing for a 20°F pinch point in the heat exchanger.

Figure 6 shows an ideal application for one or more ENTECH SunLine™ arrays where the total energy used in the home can be addressed with a single solar system rather than separate PV and thermal systems.

Figure 7 provides a schematic of a larger system for commercial, industrial and institutional applications where the solar CHP unit, or solar PV and thermal array can be combined with a conventional fossil fueled generation system to provide 24/7 energy demand. The ENTECH

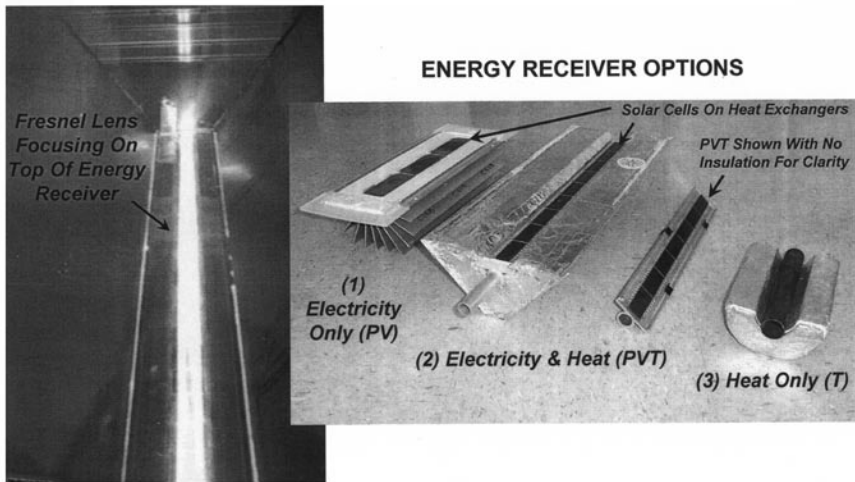

Figure 5. Photos of Module Receiver Options

SolarRow[®], shown in Figure 7, can be used to create substantial size solar arrays to meet sizable demands. SolarRows[®] can be interconnected in blocks as shown in Figure 8. ENTECH has connected its PV systems to utilities in many different areas of the U.S. The procedure is straightforward and is addressed by others in References 8 and 9.

ECONOMICS AND MARKETS

There are several items to consider in evaluating the economics of a solar combined heat and power system, part of which are summarized in Table 1.

Evaluating the economics of solar systems is somewhat different than that for conventional, fuel-based power generation systems. A solar system has a higher upfront capital cost than the conventional system. Consequently, it is generally desirable to finance the solar system over a longer term so that debt, debt/equity, or bond payments, for example, are somewhat like the ongoing fuel payments for a conventional fuel-based power system. The major difference is that once the type of solar system financing is selected along with the term of repayment and interest (or bond) rate, the monthly or annual payments are established for the term.

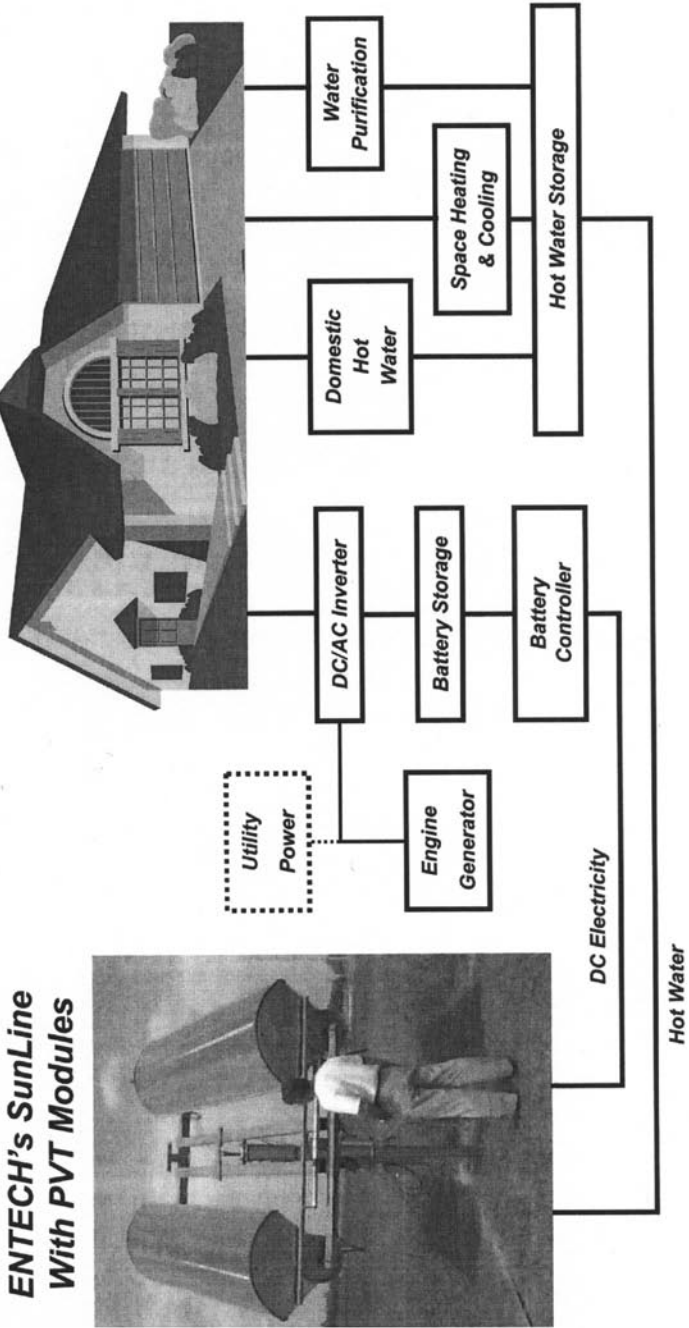

Figure 6. Total Energy Home System

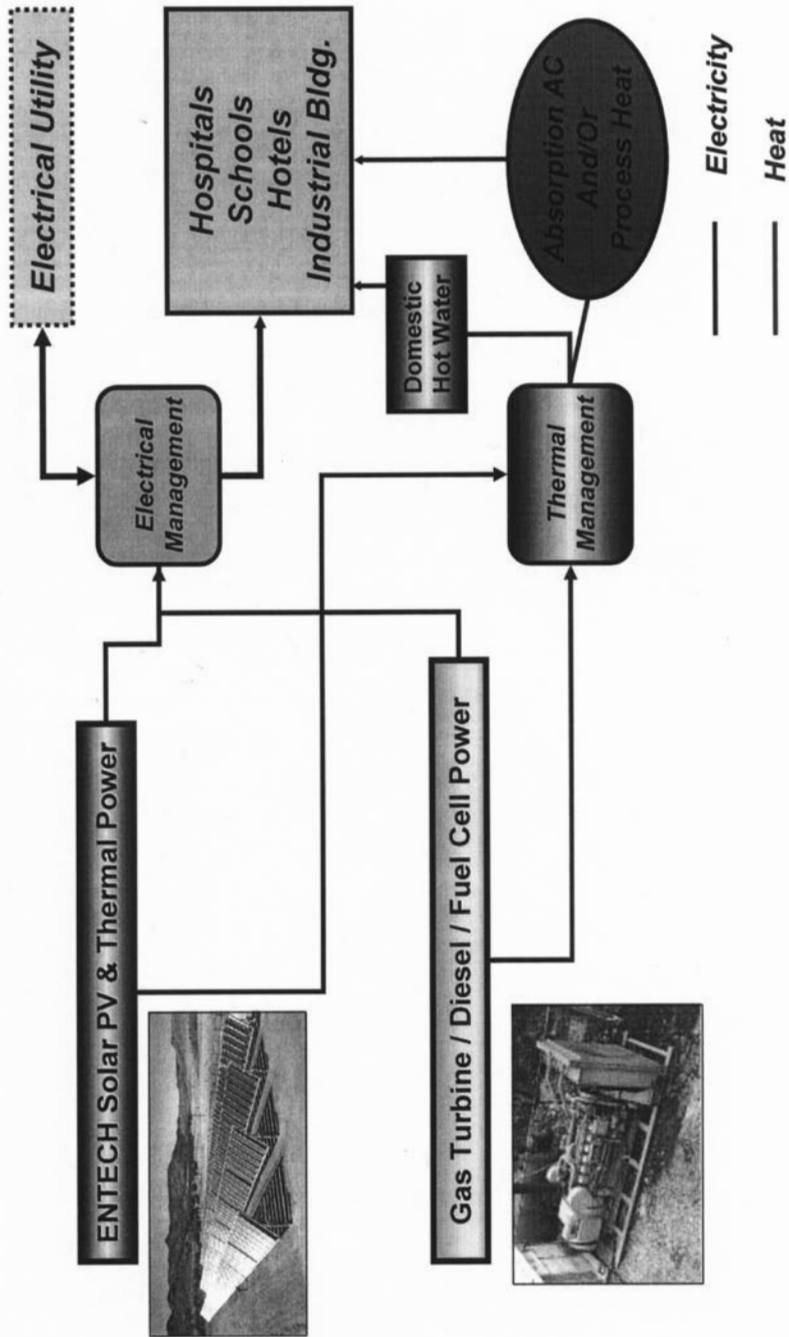

Figure 7. SolarRow[®] PVT/CHP System

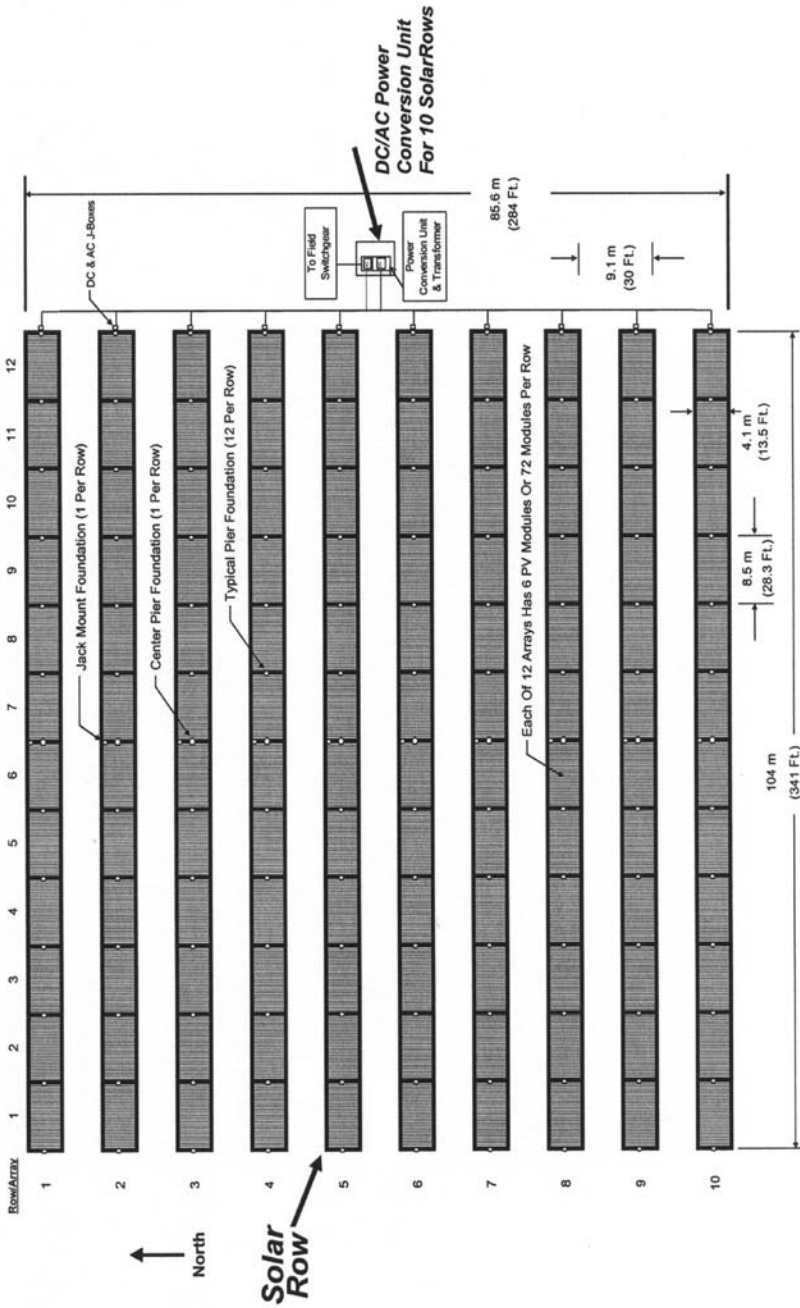

Figure 8. 10 SolarRow® System

Table 1. Brief Financial Analysis Checklist

Geographic Location

- Determine Solar Resource
 - Determine End User Connection Points and Distance
 - Determine Preliminary Grade and Sub-grade Conditions
-

Local Energy Prices for Application Site

- Current and Projected Electricity Prices
 - Current and Projected natural Gas Prices
-

Power System/ Application Matchup

- Percent Use of Direct Solar Generated Electricity
 - Percent Use of Direct Solar Generated Thermal Energy
 - Determine Preliminary Electrical and Thermal Connection Specifications
-

Solar System Price (Dependent on the Following Factors)

- Project Size
 - Solar System Production Rate
 - Local Land Area Cost
 - Applicable Taxes and Fees
 - Amount of Electrical or Thermal Storage Required (if any)
-

Power System Financing

- Direct Incentives/ Rebates Available to Project
 - Type of Financing: Debt, Equity, Combination, Bond, etc.
 - Debt Term and Interest Rate, Bond Rate, etc.
-

This established payment schedule is a highly attractive feature of solar systems because it is much different than the potential volatile price increases that may be experienced for conventional fuels over the same term, for example, 10, 20 or 30 years. It is desirable in select cases for government end energy users to utilize a long term power purchase agreement (PPA) signed with an energy provider that owns and operates the system. This is especially true if the energy provider is able to take advantage of rebates and incentives including federal and state tax credits and the accelerated depreciation available for most of the solar system.

In lieu of going into a more complicated financial model, the direct difference between using only the electrical output from a solar system compared to using both the electrical and thermal outputs is provided in a simplified example in Table 2. This table combines the effects of electricity price, thermal energy costs, geographic location (or available sunlight), and solar system cost to determine the cost effectiveness of the solar system for a given application. The annual revenue is based on the amount and price of electricity and thermal energy from conventional sources, like the electrical grid and a local, natural gas fired, hot water heater, which are offset by the solar system. The price for thermal energy in Table 2 is assumed to include burning or combustion efficiency.

The solar system cost shown in Table 2 is coded based on the production rate. The medium-shaded area is the estimated cost of the solar hardware being produced at a rate of 100 MW per year. The light-shaded area is the cost for a production rate of 10 MW per year. The area with no shade is the solar hardware cost for 1 MW per year production. In this particular simplified example, the system is assumed to be 100% financed by debt for a 30 year term at 7% annual interest rate.

The solar system is assumed to be "cost effective" when the annual revenue from the solar system is greater than the annual payment for debt principal and interest, and a small operation and maintenance cost. Electricity prices from 4 to 20 cents per kWh are considered along with thermal energy costs of \$5 to \$10 per thousand cubic feet (MCF) (~ 1 million Btu) of natural gas. As an example, a thermal energy cost of \$5/MCF assumes \$4/MCF was paid for natural gas to heat water in an 80% efficient hot water heater.

To make a comparison of PV only and PV with a thermal output option (labeled CHP or PVT) in Table 2, consider an average electricity price of 14 cents/kWh over the term of the 30 year debt as an example. The estimated annual revenue for a PV-only system in Los Angeles is not sufficient to deem it cost effective. However, if the PV-only system is located in Daggett, CA, and installed at a price commensurate with a 100 MW per year production line, it is in the cost effective range. Moving across on the 14 cents per kWh line indicates that a PVT system in LA would be cost effective if the thermal energy being offset costs \$5/MCF and the solar system was produced at rate of 100 MW per year. If everything else stays the same but the location of the solar system is changed from LA to Daggett, the system would be cost effective at a solar system production rate of 10 MW per year. As one continues to the right in Table 2 along

Electricity Price	PV Only		CHP or PVT Only			
	Electricity Only		\$5/mcf		\$10/mcf	
	LA	Daggett	LA	Daggett	LS	Daggett
4	\$61,803	\$98,157	\$169,634	\$269,419	\$277,465	\$440,680
6	\$92,704	\$147,235	\$200,535	\$318,497	\$308,367	\$489,759
8	\$123,605	\$196,314	\$231,436	\$167,576	\$339,268	\$538,837
10	\$154,506	\$245,392	\$262,338	\$416,654	\$370,169	\$587,916
12	\$185,408	\$294,471	\$293,239	\$465,733	\$401,070	\$636,994
14	\$216,309	\$343,549	\$324,140	\$514,811	\$431,972	\$686,073
16	\$247,210	\$392,628	\$355,042	\$563,890	\$462,873	\$735,151
18	\$278,111	\$441,706	\$385,943	\$612,968	\$493,774	\$784,230
20	\$309,013	\$490,785	\$416,844	\$662,047	\$524,675	\$833,308
Capacity: 1 MW Electrical Capacity						
Code	No shade – Cost effective at 1 MW annual production rate					
	Light shade – Cost effective at 10 MW annual production rate					
	Medium shade – Cost effective at 100 MW annual production rate					
	Dark shade – Not cost effective at 100 MW annual production rate					
Definition:	Cost effective = Annual revenue greater than annual payments					
Notes:	No rebates or incentives included in the numbers above.					
	Annual payments based on 100% debt financing; 30 years at 7% interest					
	Annual revenue from off-set of electricity and natural gas					
	Solar Resource, DNI					
	LA ~ 1,750 kWh/yr-sq.m.					
	Daggett ~ 2,730 kWh/sq.m.					

Table 2. Estimated Annual Revenue from CHP Solar System

the same 14 cents/kWh line, it is shown that in Daggett with \$10/MCF thermal energy costs, the system is cost effective even with a solar system cost based on a production rate of 1 MW per year.

For a more detailed financial evaluation of specific projects, ENTECH uses a financial model that includes hour by hour electricity rates from utility rate schedules, federal and state tax credits, accelerated depreciation, rebates, incentives, local hour by hour estimates of solar energy availability, debt percent, debt term and interest rate, to examine after-tax internal rate of return on project equity. This model demonstrates that ENTECH's CHP solar system provides good rates of return for a board range of geographic locations for today's standard utility rate schedules for electricity and natural gas in California.

It is estimated that the distributed generation applications will grow significantly [10] with 28 GW of new potential, three-quarters of which might be CHP applications. With the added benefits of solar CHP, it could be poised to capture a sizable portion of this market.

SUMMARY

A unique photovoltaic system is available that provides combined heat and power to substantially improve its cost effectiveness for a wider range of available sunlight conditions, and offsetting electricity and thermal energy prices. With today's conventional energy price increases, this PV CHP system will allow early market penetration for end users of both electricity and hot water, such as hospitals, hotels, prison facilities, schools, commercial laundries, etc. Later when combined with heat-driven air-conditioning systems and sustainable fueled generators, the system will be able to provide energy users with the bulk of their energy needs.

References

- [1] M. Avinash and K. Kumar. "Distributed Generation and Its Social Impact," *www.energysavingnow.com/paper/ggindia*.
- [2] "U.S. Department of Energy, Distributed Energy Program Fact Sheet." *www.eere.energy.gov*, 2004.
- [3] "US Department of Energy, Distributed Energy Program," *www.eere.energy.gov/de/index.html*, 2004.
- [4] "Sustainable Energy: Combined Heat and Power," United Kingdom Department for Environment, Food and Rural Affairs.

-
- www.defra.gov.uk/environment/energy/chp/index.htm*, 2004.
- [5] "President Bush's letter to the 26th World Energy Engineering Congress," *www.aeecenter.org/news/bushletterwebsite2003.jpg*, September 12, 2003.
- [6] L. Merrill, "Solar Power Rising, " *www.forester.net/de_0311_solar.html*, Forester Press, Nov / Dec 2003.
- [7] *www.entechsolar.com*
- [8] B. Verhoeven, "Utility Aspects of Grid Connected Photovoltaic Power Systems," Report IEA PVPS T5-01:1998, December 1998.
- [9] S. Varming, C. Gardestrup, and J.E. Nielson, "Review of Technical Options and Constraints for integration of Distributed Generation in Electricity Networks," SUSTELNET Project, *www.sustelnet.net*, Energy Research Center of the Netherlands, March 30, 2004.
- [10] E.J. Honton (Technical Contact), "The Potential U.S. Market for Distributed Generation: 2004 Edition," Resource Dynamics Corporation, Vienna, VA, 2004.
-

ABOUT THE AUTHOR

Dr. Walters is vice president of corporate business, development & marketing for ENTECH, Inc., a solar energy company headquartered in Keller, Texas, in the Dallas-Fort Worth area. He is one of the owners and founders of the company. His work takes him throughout the United States and outside the U.S. working with customers and government representatives in most of the sun-belt countries. He was appointed by the governor of Texas to serve on the Texas Energy Coordination Council to develop an energy policy for Texas. He was president of the Texas Solar Energy Industries Association, has served as president and a member of the board of directors of the Texas Renewable Energy Industries Association, and was previously the chair of the Greater Fort Worth Sierra Club. Dr. Walters was program manager for the 3M/ Austin 300 kW Photovoltaic Project, which was the largest PV system in the world at the time. Prior to getting into the solar energy business, he served in variety of engineering positions with the LTV Aerospace Corporation and E-Systems. He has authored many technical and business development papers. Dr. Walters earned his B.S., M.S., Ph.D. in aerospace and mechanical engineering at the University of Oklahoma.

His email address is *walters@entechsolar.com*. He can also be contacted at ENTECH, Inc., 1077 Chisolm Trail, Keller, Texas, 76248 USA.