Analysis of Water Seepage Mechanism and Study on Mechanical Properties of Highway Tunnel Based on Fluid-Structure Coupling

Li Qing and Lu Hao*

*Guangdong Transportation Technology Testing Co., Ltd., GuangZhou, Guangdong,
510550, China*

E-mail: lhchd0220@126.com

**Corresponding Author*

Received 10 April 2024; Accepted 23 May 2024

Abstract

Shaoguan was hit by a extremely heavy rainstorm, and the mountain water catchment of Dabaoshan Tunnel in the southern section of Beijing Hong Kong Macao Expressway in Guangdong increased sharply. Due to the rapid rise of groundwater level, water and mud gushed at ZK141+227 of Dabaoshan, and serious water seepage occurred in other areas, bringing soil into the tunnel, which seriously hindered the safe passage of the tunnel. According to the on-site investigation of water and mud gushing, it was found that there were branches sandwiched in the mud gushing out, and at the same time, it was found that there was water leakage at the foot of some walls where drainage holes were added. Based on the fluid structure coupling mechanism, the seepage mechanism of highway tunnels was deeply explored, and the mechanical properties of tunnels under seepage were analyzed through experimental data and numerical simulation. The experimental results show that under the action of seepage, the stress distribution of the

European Journal of Computational Mechanics, Vol. 33_2, 121–144.

doi: 10.13052/ejcm2642-2085.3322

© 2024 River Publishers

tunnel lining changes, and the phenomenon of local stress concentration is obvious. When the seepage pressure reaches 3.5 MPa, cracks appear in the tunnel lining, with a total of 5 cracks. The distribution of cracks is closely related to the seepage field. The numerical simulation further reveals the interaction mechanism between the seepage field and the tunnel structure, confirming the influence of the seepage field on the stability of the tunnel lining. When the seepage pressure increases to 4.0 MPa, the displacement change rate of the tunnel lining reaches 0.3 mm/m, and the maximum lining stress is 15.7 MPa. The purpose of this study is to propose a maintenance plan for highway tunnels to improve their safety. Consider the impact of seepage on tunnel structure and adopt effective waterproofing and drainage design. Further research on the seepage mechanism and tunnel mechanical properties is recommended to provide more reliable theoretical support for engineering applications.

Keywords: Fluid-structure interaction, seepage mechanism of highway tunnel, mechanical properties, stability of tunnel lining.

1 Introduction

The southern section of the Beijing Hong Kong Macao Expressway is located in Guangdong Province, China. It is an important component of the national five vertical and seven horizontal planning project of the Beijing Hong Kong Macao Expressway in Guangdong Province. The Guangshao Expressway starts from Xiaotang in Lechang City, Shaoguan City in the north, connects to the Leiyi section of the Beijing Hong Kong Macao Expressway, passes through Qujiang, Wengcheng in Wengyuan County, Yingde and Fogang in Qingyuan City, Conghua and Huadu in Guangzhou City, and ends in Taihe Town, Baiyun District, Guangzhou City in the south. It is connected to the Guangzhou North Second Ring Expressway and the South China Expressway. The Shaoguan section of the southern section of the Beijing Hong Kong Macao Expressway is located in the mountainous area of northern Guangdong, with the terrain mainly consisting of mountains and heavy hills. The terrain and geological conditions along the line are complex, and the cutting slopes are high and steep, mostly located in areas with extremely poor geological conditions. On May 10, 2018, Shaoguan was hit by a extremely heavy rainstorm, and the mountain catchment of Dabaoshan Tunnel in the southern section of Beijing Hong Kong Macao Expressway in Guangdong

increased sharply. Due to the rapid rise of groundwater level, water and mud gushing and serious water seepage occurred in Dabaoshan.

Groundwater will have a significant impact on the construction and operation of tunnel engineering, and the seepage field formed by the surrounding rock of the tunnel will have a significant mutual influence with the stress field of the surrounding rock. On the one hand, tunnel excavation can easily disturb the stress field of rock and soil, thereby changing the physical and mechanical properties of rock and soil, especially the changes in rock and soil permeability, which can seriously affect the distribution of surrounding rock seepage field [1, 2]. On the other hand, surface water can provide approximately infinite water supply to groundwater, and the redistribution of the seepage field around the tunnel will change the permeability pressure of rock and soil particles, thereby altering the stress state of the rock and soil. The coupling of seepage field and stress field in underground engineering will have complex effects on surrounding rock and support structure. Therefore, when analyzing the stability of tunnel surrounding rock under the influence of seepage field, the coupling effect of seepage field and stress field must be considered. Many experts and scholars have systematically studied the principle of fluid structure coupling during tunnel excavation. Based on this, the Lagrangian fast finite difference method is used to deeply analyze the effects of construction methods, rock mass grade, steel reinforcement ring thickness, and permeability coefficient on rock mass stability, seepage law, and support structure stress. A series of important research results have been achieved [3, 4].

Highway tunnels are an important component of modern transportation infrastructure, and their safety and durability are of great significance for ensuring road traffic and promoting economic development. Highway tunnels often face water seepage problems, which pose serious safety hazards and shorten the service life of tunnels. Understanding the seepage mechanism and mechanical characteristics of tunnels is crucial for effective design, maintenance, and safety [5].

The fluid solid interaction involves the interaction between fluids and solids, which is of great significance for understanding geological hazards, oil and gas extraction, hydraulic structures, and other fields. In highway tunnels, the interaction between seepage field and tunnel structure is also a typical fluid structure coupling problem [6, 7]. This study aims to study the seepage mechanism of highway tunnels based on the fluid structure coupling mechanism, and analyze the mechanical properties of tunnels under

seepage through experiments, providing theoretical basis for the design and maintenance of Dabaoshan Highway Tunnel.

2 Study on Mechanical Properties of Assembled Inverted Arch Joint under Fluid-Structure Coupling

2.1 Assembled Inverted Arch Structure

Mine method is usually used in mountain tunnel construction, and its support system includes primary support and secondary lining, among which the secondary lining includes bottom inverted arch structure and upper arch wall lining structure. Inverted arch is a reverse arch structure set at the bottom of the tunnel to improve the stress condition of the upper supporting structure, and it is one of the main components of the tunnel lining structure. On the one hand, the inverted arch can effectively transfer the stratum pressure and pavement load on the upper part of the tunnel to the ground through the side wall structure of the tunnel, and at the same time, it can effectively resist the reaction force from the lower stratum of the tunnel [8]. The inverted arch and the second lining of arch wall are closed into a ring to form the whole tunnel lining, which increases the structural stability.

At present, in the construction of mine tunnel, the invert arch usually adopts formwork concrete structure, which needs to complete many processes such as binding steel bars, erecting formwork and pouring concrete in the tunnel, and the construction speed is slow [9, 10]. The slow construction speed of invert arch will affect the backfilling pouring of upper invert arch and prolong the backfilling pouring time of invert arch later; Secondly, because the second lining of arch wall can only be constructed after the backfilling and pouring of inverted arch is completed, the slow construction speed will prolong the construction completion time, and then affect the time for the tunnel lining to be closed into a ring, which is extremely unfavorable to the stability of the tunnel; Thirdly, in the current tunnel construction, trestle bridges will be erected in the inverted arch construction section, which will make it difficult for vehicles to pass through the tunnel. Because of the narrow trestle bridges, the risk factor of vehicles passing through is high, and the cast-in-place inverted arch makes the step time longer, which is not conducive to the traffic and construction safety in the tunnel.

The surface investigation of the tunnel mountain is mainly based on the results of previous regular tunnel inspections, tunnel disasters, hydrogeological and engineering geological conditions. The hydrogeological and

engineering geological investigation methods are used to investigate the current situation of surface collapse and drainage facilities. The investigation content is as follows:

- (1) Tunnel mountain surface collapse
 - (a) Is there any new collapse or development, as well as the location, shape, size, and other characteristics of the collapse.
 - (b) Stable situation of old collapse
 - (c) Whether there are geological hazards such as landslides, collapses, and ground fissures at the top of the cave, and the development of surface vegetation.
- (2) Drainage facilities
 - (a) Investigation of the complete condition of drainage facilities on the mountain body of the tunnel; Whether there are tensile cracks, intact conditions, unobstructed conditions, etc.
 - (b) Assessment of terrain characteristics and catchment area.

By measuring approximately 3 km² in the Dabaoshan Tunnel area, conduct a large-scale (1:1000) fine hydrogeological and engineering geological survey within the scope to clarify the topography, geological structure, stratigraphic lithology, adverse geological phenomena (karst caves, collapses, etc.) of the Dabaoshan Tunnel, and lay the foundation for the next step of groundwater connectivity testing.

Cast-in-place invert arch will not only affect the construction speed of invert arch, but also cannot guarantee its construction quality. Figure 1 presents the process analysis of highway tunnel assembly architecture. First,

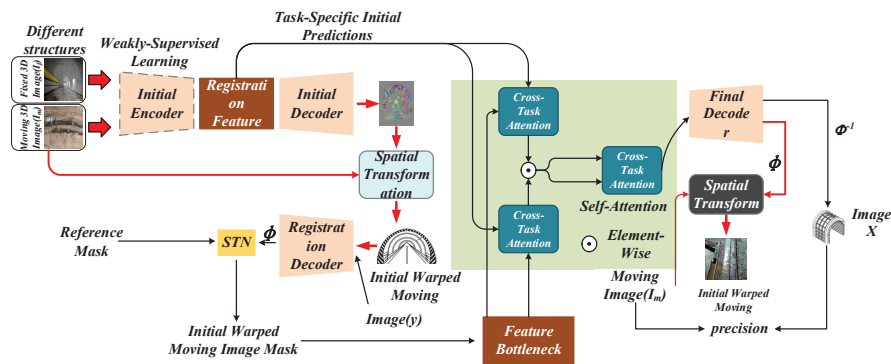

Figure 1 Process analysis of highway tunnel assembly architecture.

in order to reduce the construction time, many construction units will choose one-time pouring of inverted arch and inverted arch backfilling. Because the concrete grade used in inverted arch backfilling is generally lower than that of inverted arch, it will lead to the inverted arch not reaching the design strength. On the other hand, one-time pouring of inverted arch and inverted arch backfilling is not conducive to tunnel stability, and cannot play the role of inverted arch, which will make the top of inverted arch backfilling tension, resulting in pavement cracking and bottom uplift; Secondly, the quality of cast-in-place invert arch cannot be guaranteed. Under the comprehensive action of in-situ stress, vehicle load and groundwater in the later period, the invert arch will crack and break, which makes the tunnel lining unable to be closed into a ring, which is not conducive to the stress and stability of the tunnel [11, 12].

At present, there are mainly the following attempts for prefabricated invert arch: full ring prefabrication, that is, prefabricating invert arch as a whole, which has good integrity, but heavy weight, high requirements for hoisting machinery, and large requirements for field working space, which is not conducive to use in tunnels [13, 14]; Connecting precast blocks with bolts is simple and easy to operate, but the requirements for concrete are high, and c35 and c40 concrete used in lining of mountain tunnels cannot give full play to the role of bolts; Positioning concave-convex groove and other connection methods, which are reliable and safe, but the connection process is too cumbersome, and the structure of the joint of invert prefabricated block is complex, which is not conducive to the production of templates and the later demoulding process. Therefore, based on this, it is necessary to find a new type of prefabricated inverted arch structure.

2.2 Fluid-structure Coupling

The important feature of fluid-structure coupling mechanics is the interaction between two-phase media [15, 16]. Deformed solid will deform or move under the action of fluid load, which in turn affects the flow field, thus changing the distribution and size of fluid load. It is this interaction that will produce various fluid-structure coupling phenomena under different conditions [17]. Fluid-solid coupling problem can be defined by its coupling equations. The domain of this set of equations includes fluid domain and solid domain at the same time, while the unknown variables include variables describing fluid phenomenon and variables describing solid phenomenon. Generally speaking, it has two characteristics: neither fluid domain nor solid

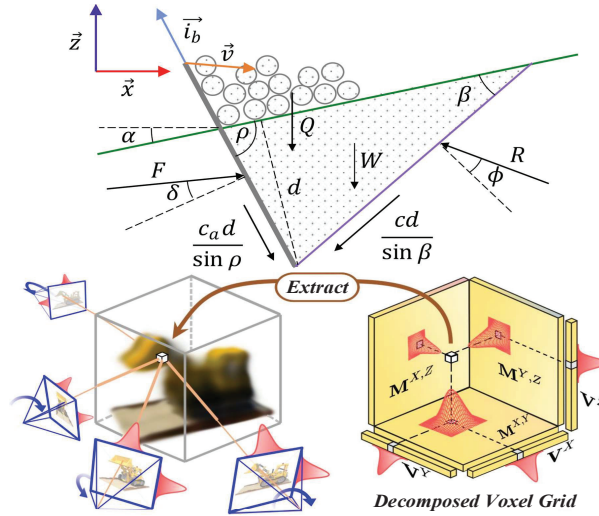

Figure 2 Fluid-structure coupling analysis of underground reservoir.

domain can be solved independently; It is impossible to explicitly eliminate independent variables describing fluid motion or solid motion.

Underground reservoir is a combination of porous media of solid, liquid and gas. Classical seepage mechanics has studied the fluid flow in solid pores deeply, but it does not involve the fluid-solid coupling problem. In the process of oil and gas exploitation and groundwater drainage, due to the change of fluid pressure in porous media, on the one hand, it will cause the change of solid characteristics; On the other hand, these changes in turn affect the fluid flow and pressure distribution in porous media. Therefore, in many cases, it is necessary to consider the interaction force between fluid, including liquid (oil or water), gas (natural gas, coal mine gas, etc.) and porous media, that is, the coupling effect between stress field and seepage field in porous media should be considered [18, 19].

Figure 2 shows the fluid-solid coupling analysis of underground reservoir. The remarkable feature of fluid-solid coupling problem of underground reservoir is that solid region and fluid region contain each other and are intertwined with each other, which is difficult to be clearly divided. Therefore, fluid phase and solid phase must be regarded as overlapping continuums, and interaction can occur between continuums of different phases. This characteristic makes the governing equations of the fluid-structure coupling problem need to be established according to specific physical phenomena, and the fluid-structure

coupling effect is also reflected by the governing equations. That is to say, in the governing equations describing fluid motion, there are terms reflecting the influence of solid deformation, while in the governing equations describing solid motion or equilibrium, there are terms reflecting the influence of fluid flow.

2.3 Mechanical Properties of Fabricated Inverted Arch Joint

The prefabricated tunnel invert arch comprises a plurality of rows of assembling units arranged sequentially along the tunnel extension direction, each row of assembling units comprises a plurality of assembling blocks with arc cross sections, joints between adjacent assembling blocks in each row of assembling units and joints between adjacent assembling blocks in adjacent assembling units are staggered with each other, and steel bars for connecting with tunnel arch walls are embedded at the tops of prefabricated blocks on both sides of each row of assembling units. The seams in the odd-numbered row assembly units of the plurality of rows of assembly units correspond to each other, and the seams in the even-numbered row assembly units correspond to each other [20, 21].

Prefabricated blocks have hoisting rings, positioning protrusions/grooves, and can connect via tenon-groove or ball hinge types. They are detachably connected by connecting pieces and have water stop strips [22]. A vertical grouting hole penetrating the prefabricated block is reserved on the prefabricated block in the middle of each row of assembling units. In the tunnel structure, primary support, secondary lining, drainage system and filling layer are arranged in turn from outside to inside on the inner surface of the tunnel. The secondary lining includes tunnel arch wall and prefabricated tunnel invert arch as above.

Figure 3 shows the power control system of the drainage system. The drainage system employs a prefabricated drainage system that includes horizontal and inclined blind drains within the filling layer, inspection wells, and inverted arch bottom drains within the initial support. The inspection wells are installed on the horizontal drainage pipes within the filling layer. The system also includes longitudinal drainage ditches on both sides of the filling layer, with the inclined blind drain connected to the inspection wells and ditches. The drainage system uses detachable connections for the horizontal and inclined drains, inspection wells, and inverted arch drains. The drainage components are prefabricated, with two longitudinal drainage ditches on each side separated by a waterstop belt. The joint of the longitudinal drainage ditch

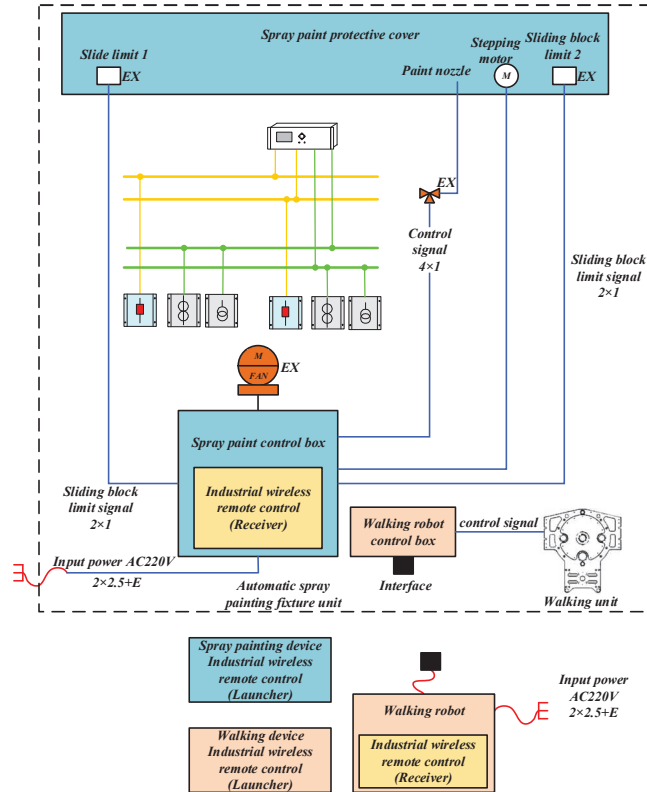

Figure 3 Power control system of drainage system.

and the filling layer drainage inclined blind pipe is located above the bottom of the longitudinal drainage ditch.

Prefabricated tunnel invert arch, tunnel structure and construction method thereof by connecting different rows of assembled units in staggered joints along the tunnel extension direction, the tunnel invert arch is stressed more evenly and is not easy to deform, thus preventing tunnel cracking [23, 24]. Because the tunnel invert arch is formed by splicing a plurality of precast blocks with arc cross sections, it is not only convenient for batch prefabrication of precast blocks in factories, but also convenient for transportation and installation. Each precast block can be transported to the construction site for on-site installation, and the installation is fast and simple, thus realizing the rapid construction of tunnel invert arch, reducing the labor intensity of workers, improving the construction efficiency and ensuring the construction

quality, so as to avoid the quality hidden danger brought by the cast-in-place operation of tunnel invert arch. In addition, it has the advantages of saving resources and energy, reducing construction pollution and improving quality and safety level in the construction process. It can also prevent the hidden dangers of uneven stress, easy deformation and easy cracking of the tunnel. Formula (1) and formula (2) are the formulas for calculating flow rate and shear stress respectively. Formula (3) and formula (4) are the formulas for calculating compressive stress and viscosity respectively.

$$Q = \frac{A \times \Delta P}{L} \quad (1)$$

$$\tau = \frac{6 \times \eta \times v}{D} \quad (2)$$

$$\sigma = \rho \times g \times h \quad (3)$$

$$\eta = \frac{\mu}{\rho} \quad (4)$$

3 Analysis of Water Seepage Mechanism of Highway Tunnel

3.1 Overview of Tunnel

The Dandong-Tonghua section of Heda Expressway was opened to traffic on September 26, 2012, with a total length of 197 kilometers. It starts at the junction of Liaoning and Jilin and ends at Guchengzi Village, Dandong. Along the way, it crosses the eastern mountainous area of Liaoning Province, which is mountainous and hilly. The bridge-tunnel ratio of expressway is as high as 30%, especially from Dandong to Huanren. There are 48 tunnels in Dandong section of Heda Line, with a total length of 45,241 meters. The tunnels are densely distributed, including 2 extra-long tunnels, 38 medium-long tunnels and 8 short tunnels [25, 26]. Affected by marine monsoon, Liaodong area has large annual rainfall and abundant groundwater resources. At the same time, it is located in the north and has low temperature in winter, which belongs to seasonal frozen area. Winter is cold and long, and frost lasts for a long time. Since it was put into operation in September 2012, after nearly seven years of daily and regular inspection of 48 tunnels, it was found that more than 30 tunnels had different degrees of water leakage in winter, and the water leakage disease in winter has become the main disease of tunnels.

For operating highway tunnels, the key to water damage assessment and treatment lies in accurately identifying the source and channel of leakage water. The detection of cavities (karst caves) or water bodies behind the tunnel lining is very important, which directly affects the accuracy of evaluation and the effectiveness of treatment. Due to the significant difference in physical properties between water and soil, geophysical methods are feasible and effective in detecting cavities (caves) or water bodies behind lining. For operating tunnels, seismic imaging method is an effective method for detecting karst caves around the tunnel. In this work, an American made NZ24 shallow seismic instrument and a domestically produced reflection detector were used.

The seismic imaging method is a special case of the best offset technique for collecting effective waves in the reflection wave method. In order to obtain seismic imaging records with high signal-to-noise ratio and wide frequency band, a certain length of experimental profile was obtained using multi-channel seismometers in the work area. By analyzing the frequency, propagation speed and time, amplitude, and interrelationships of various waves on the experimental profile, the optimal offset distance was determined to best reflect the effective wave offset of the detection target. The actual situation shows that a smaller optimal offset can better utilize the characteristics of seismic imaging method. The seismic imaging method uses a smaller seismic detection distance for single channel operation, and the terrain has little influence on it. For gently inclined reflection surfaces, they are basically vertically incident, especially according to the optimal window theory. A smaller seismic detection distance can effectively avoid surface wave interference. As a seismic method, seismic imaging has basically all the advantages of seismic wave reflection method in shallow exploration engineering applications. It can be applied in geological boundaries, structural exploration, karst detection, anti cavity detection, goaf detection, and other aspects. Moreover, it has the advantages of simple and easy to operate working methods, making it a relatively superior working method in engineering seismic.

3.2 General Situation of Water Seepage Diseases

Every year to the end of November, some tunnels have different degrees of water leakage until the end of April of the following year. It brings great hidden dangers to the driving safety of expressways. The construction of tunnels destroys the original water system balance of mountains, and the tunnels become the channels for groundwater gathering near the mountains.

In the waterproof and drainage construction of tunnels, the process quality is not up to standard, which easily leads to the phenomenon of tunnel water leakage. Through the observation of tunnel water leakage in the pipe section, it is found that the leakage points are mainly concentrated in four parts: water leakage at the construction joint; Water gushing at the arch foot of the side wall; Water gushing in the transverse tunnel of the vehicle or the transverse tunnel of the pedestrian; Pavement backwater caused by central flower tube blockage [27, 28].

Water seepage in highway tunnels reduces the service performance of tunnels and seriously threatens the normal operation safety. Affected by low temperature, the tunnel with water leakage point located in the arch will form icicles at the water leakage point and hang at the vault or arch waist. If it is not treated in time, the hanging ice will fall off and pose a threat to passing vehicles. When the water seepage is large, the hanging ice will accumulate more and more to form giant icicles, which will invade the tunnel building clearance and seriously endanger driving safety [29]. The tunnel drainage ditch is blocked by ice, which makes the tunnel drainage difficult, the ditch is damaged by freezing crack and destroys the tunnel drainage system; When there is a large amount of leakage water in the tunnel and there are many leakage points, a large area of ice will be formed on the tunnel pavement, which will easily lead to traffic accidents. Under the influence of frost heaving at low temperature, the leakage water of tunnel will invade the gap of fireproof spraying and side wall tiles, which will cause the spraying and tiles to bulge and fall off, which will have adverse effects on the ancillary facilities in the tunnel, and affect the driving comfort and the beauty in the tunnel. Water leakage will cause damage to power facilities in tunnels to varying degrees. Most of the ventilation and lighting facilities in the tunnel are steel products. Water accelerates the corrosion speed of steel, affects its service life, increases the maintenance cost of the tunnel, and in severe cases, it will cause serious hazards such as short circuit, electric leakage and fire. Tunnel leakage will lead to the deterioration of lining material concrete material and sand outflow, which will relax the surrounding rock and become external load, resulting in diseases.

The calculation formulas for tunnel seepage volume, tunnel surrounding rock stress, and tunnel surrounding rock permeability are shown in Equations (5), (6), and (7).

$$Q = \frac{2\pi kH}{\ln \frac{R}{r}} \quad (5)$$

$$\sigma_r = -p + \frac{2E}{1-\nu} [\alpha_T(T - T_0) + \alpha_H(H - H_0)] \quad (6)$$

$$k = k_0 \exp\left(-\frac{b\sigma_m}{E}\right) \quad (7)$$

3.3 Occurrence Mechanism of Water Seepage Disease

The annual rainfall in eastern Liaoning is large, and the underground water resources in the mountain are abundant. After the tunnel is built, the original water system balance and stress balance in the surrounding rock are destroyed. In order to achieve the new balance, the tunnel needs to bear the internal water pressure and surrounding rock pressure. Most of the tunnels are located below the groundwater level line, which makes the water pressure behind the lining high. After long-term accumulation, it is easy to penetrate along the weak waterproof parts of the tunnel (welded joints of waterproof boards and damaged parts of waterproof boards), and generally leak into the tunnel through settlement joints or construction joints. Calcium-containing chemicals and concrete precipitates in fissure water around the tunnel can easily cause blockage of tunnel drainage system, which makes the water flow behind the lining unsmooth and unable to discharge, thus forming leakage [30].

Figure 4 is the tunnel architecture analysis. In tunnel construction, due to the selection of construction materials and construction quality problems, it is easy to cause certain defects in tunnel waterproof and drainage system, which provides a way for groundwater migration. The insulation measures of tunnel

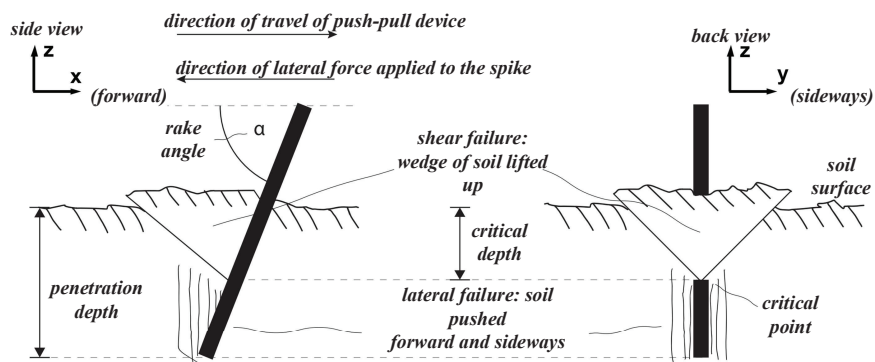

Figure 4 Tunnel architecture analysis.

waterproof and drainage system are imperfect. It is cold in winter in eastern Liaoning. According to statistics, tunnel leakage mainly occurs from the end of November to the beginning of April of the following year. During this period, the temperature in the tunnel is below 0°C for most of the time, and the limit temperature reached -29°C. Therefore, low temperature is the main factor affecting tunnel leakage. The insulation measures of tunnel waterproof and drainage system can not meet the actual requirements, and water icing leads to poor water flow in tunnel waterproof and drainage system. Due to the failure to dredge in time, some longitudinal drainage pipes, inspection wells of longitudinal drainage pipes and transverse drainage pipes in the tunnel are seriously blocked, which leads to the water behind the lining being unable to be discharged and the water pressure rising continuously, forcing the water flow to flow out along the weak waterproof part of the lining, resulting in leakage. In addition, the water outlet section of the central flower tube hole in the tunnel is frozen and blocked, which leads to the difficulty of drainage in the tunnel and also leads to water leakage. The formulas for calculating pressure difference and thermal conductivity are shown in Equations (8) and (9). The calculation formulas of thermal expansion coefficient and strain energy density are shown in Equations (10) and (11).

$$\Delta P = \frac{4 \times \mu \times Q}{A} \quad (8)$$

$$\lambda = \frac{k}{\rho c} \quad (9)$$

$$\alpha = \frac{k}{\rho c} \quad (10)$$

$$\sigma = E \times \epsilon \quad (11)$$

There are defects in tunnel waterproof system. In the construction process, there are some construction problems, such as the waterproof board is punctured and damaged, the waterproof board is not welded tightly enough and there are gaps, the gap between the waterproof board and concrete is too large, the waterstop is missing or the installation is reversed, etc. Due to the influence of construction quality, material quality and other factors, the waterproof layer is easy to be damaged during tunnel operation, and the water behind the lining is easy to gather at the construction joint, which often causes water leakage at the construction joint, especially at the corner. The formulas

Table 1 Determination of effect of PH value on lining in tunnel leakage

Effect on Concrete	Determination Result
Cement dissolution and collapse	Hazardous
Uneven surface within a short period of time	Hazardous
Surface prone to damage	Attention Required
Caution needed during initial use of concrete	Relatively Safe
/	Safe

for pressure difference and shear stress are shown in Equations (12) and (13), and the formulas for density and pressure difference are shown in Equations (14) and (15).

$$\Delta V = \frac{\Delta P}{Z} \tag{12}$$

$$\tau = \frac{4 \times Q}{A} \tag{13}$$

$$\rho = \frac{m}{V} \tag{14}$$

$$\Delta P = \frac{L}{D} \times 4 \times \mu \times v \tag{15}$$

The construction of tunnel drainage system is imperfect. Due to the construction problems, the connection between the inner circumferential blind ditch, longitudinal drainage pipe and transverse drainage pipe in the tunnel is not solid, and a closed loop cannot be formed. Water flows out from the drainage gap and forms leakage. Due to the large drainage demand in some tunnels, the transverse drainage pipes in the transverse tunnels cannot meet the drainage requirements, and the excessive water accumulation causes water gushing in the transverse tunnels of vehicles and pedestrians. Table 1 presents the determination of the impact of pH value on the lining in tunnel leakage. Notably, if the quality, thickness, and impermeability of the secondary lining fail to meet the standard requirements during construction, it can contribute significantly to water leakage. Despite the inherent waterproof properties of the secondary lining concrete, its inadequate bonding ability with waterproof structures like rubber waterstops, often resulting from insufficient vibration during construction, can render it prone to separation under external forces. This, in turn, can cause water leakage at the construction joints.

4 Experimental Results and Analysis

4.1 Optimization Method Design

Winter is a period of frequent leakage of tunnel water. Because of the sudden occurrence, uncertainty and seriousness of leakage water and its harm, emergency treatment of tunnel leakage water is particularly important. Combined with the experience of tunnel management and maintenance in Kuandian section, two emergency treatment measures are put forward for tunnel leakage water in different situations. In this embodiment the number of longitudinal drains 77 on each side is two and a water stop strip is provided between the two longitudinal drains 77.

Figure 5 is an analysis of water leakage in the pipe section. In order to facilitate the smooth flow of water in the longitudinal drainage ditch 77 to the inspection well 74, the upper end of the filling layer drainage inclined blind pipe 72 is preferably inclined upward in the direction away from the inspection well 74, thus guiding the flow direction to a certain extent. In addition, the filling layer drainage inclined blind pipe 72 may be a solid-walled pipe or a double-walled corrugated pipe. Here, a double-wall bellows with a diameter of 50 mm to 160 mm is preferentially selected for the filling layer drainage inclined blind pipe 72, and the spacing between adjacent filling layer drainage straight blind pipes can be set to 500 mm to 1000 mm.

Highway tunnel inspection should not be less than once/week, especially in rainy season or freezing season, and the frequency of daily inspection should be increased. Kuandian area enters winter around the end of November every year, and tunnel water leakage has entered a period of frequent occurrence. During this period, emergency vehicles and tunnel maintenance personnel should be arranged to inspect the tunnel two or three times a

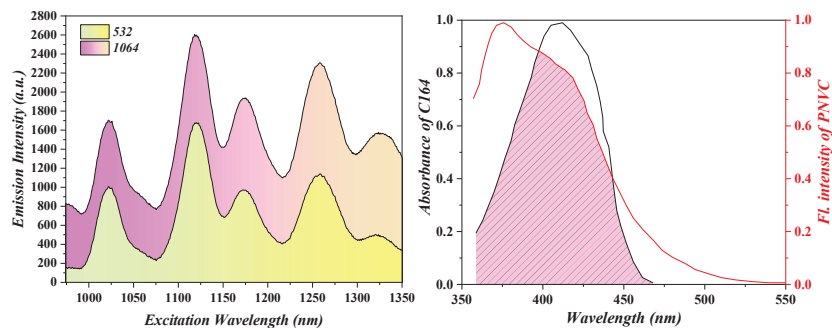

Figure 5 Analysis of water leakage in pipe section.

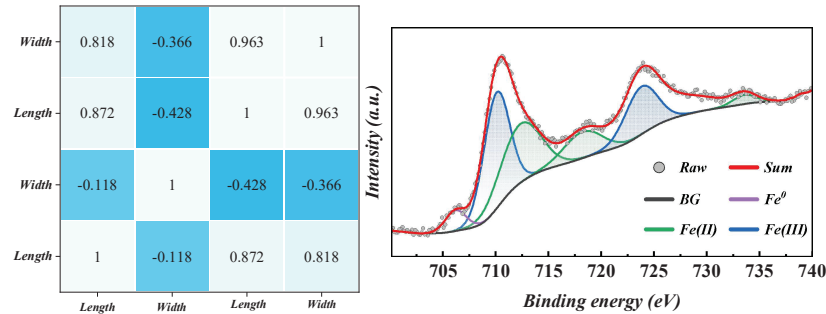

Figure 6 Analysis of tunnel disease types and characteristics.

day, focusing on observing the locations prone to water leakage diseases such as construction joints, construction joints corners, transverse tunnels and pedestrian transverse tunnels in the tunnel. Strengthen the regular inspection of the tunnel drainage system, observe the amount of water at the drainage mouth outside the tunnel, and ensure the smooth flow of the tunnel drainage system. Visual inspection on foot should be taken as the main inspection, equipped with necessary inspection tools or equipment, record the inspection results in time and sort them out for the record, so as to find dangerous situations in the first time and minimize the harm degree of tunnel water leakage.

Figure 6 is an analysis of the types and characteristics of tunnel diseases. It is preferred that the joint between the longitudinal drainage ditch 77 and the filling layer drainage inclined blind pipe 72 is located above the bottom of the longitudinal drainage ditch 77. By observing all the tunnels with water leakage in the pipe section, it is found that the water seepage at most leakage points is small, and the water seepage points often stop leaking because of freezing, and the water seepage time is maintained within one to two days. For tunnels where leakage has occurred, warning signs for passing vehicles shall be given at leakage points or frozen places. In tunnels with icicles hanging on the vault, lifting vehicles and workers should be arranged to remove icicles in time. In tunnels with icy roads, personnel should be arranged to carry out manual deicing. After deicing, appropriate amount of anti-skid agent should be distributed to prevent secondary freezing. In view of the large amount of water leakage, the water leakage lasts for several days, and the road surface freezes in a large area, the method of erecting diversion facilities (drainage grooves and drainage pipes) at the water leakage point or arranging vehicles to receive water and transport it outside the tunnel is

adopted. At the same time, personnel are organized to carry out deicing and anti-skid work, and construction safety should be done in manual operation. If necessary, roads should be closed and personnel should be provided to clear traffic.

4.2 Result Analysis

For the leakage points with large water leakage in the tunnel, the method of picking grooves is adopted to guide the water away and discharge, so as not to make it diffuse and erode. The specific construction method is to drill holes at the water leakage point (construction joint position) to drain water. After drilling, an inverted trapezoidal groove is drilled vertically from the hole. The bottom of the groove should fall on the seepage crack. The concrete residue in the groove should be removed with a steel wire brush and the groove and its surroundings should be washed with clear water. Then the PVC drain pipe (wrapped with permeable cloth) should be fixed in the groove, and the water should be directly led to the central flower pipe of the tunnel for discharge. Electric tracing belts should be provided around the drain pipe. Finally, waterproof mortar should be smoothed and coated with waterproof surface protection agent (about 1.5 mm thick).

The results of geophysical exploration in this tunnel:

- (1) There are a total of 66 abnormal areas in the tunnel, which are speculated to be karst developed areas.
- (2) The width of the anomaly is between 2.0 and 38.0 m, and the height is between 1.1 and 4.0 m. These abnormal areas may be connected to their surrounding karst or fissures, providing a good channel for groundwater circulation, leading to the occurrence of tunnel seepage, wall rupture and detachment, and other diseases.
- (3) Karst and tunnel diseases are mainly concentrated in the ZK140+357-ZK140+437 and ZK141+147- ZK141+207 sections.

Figure 7 shows the solution analysis of tunnel water leakage. The filling layer drainage straight blind pipe is preferably located 30 cm below the top surface of the filling layer, and one side of the pipe wall of the filling layer drainage straight blind pipe is provided with a water inlet hole. The diameter of the longitudinal blind tube 73 is preferably 100 mm to 200 mm. Similarly, the inverted bottom drainage blind pipe 76 may be a solid-walled pipe or a double-walled corrugated pipe. In this embodiment, the invert bottom drainage blind pipe 76 preferentially adopts a double-wall corrugated pipe with a diameter of 200 mm to 400 mm, the invert bottom drainage blind pipe

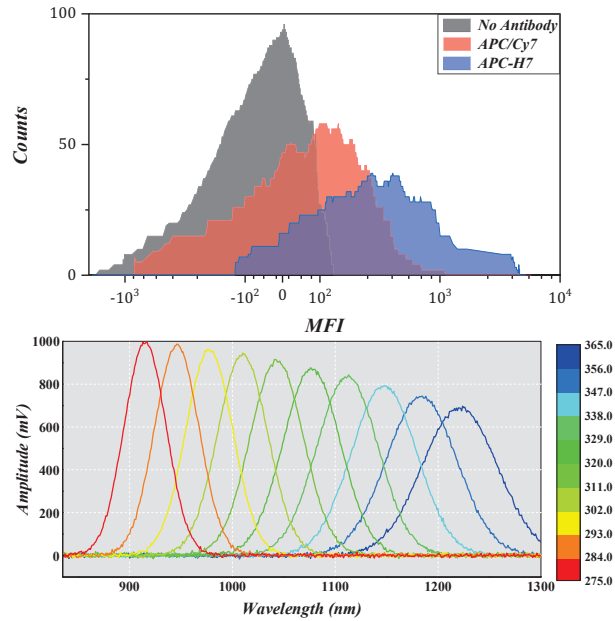

Figure 7 Tunnel leakage solution analysis.

76 is located within 100 mm to 2000 mm below the invert, and a water inlet hole is also arranged on the upper side of the invert bottom drainage blind pipe 76. For the transverse drainage pipe in the transverse tunnel can not meet the drainage requirements, which leads to water gushing in the transverse tunnel, the method of adding transverse drainage pipe can be adopted. Chisel a groove below the original transverse drainage pipe, put a drainage pipe with appropriate diameter and connect it with the longitudinal drainage pipe and circumferential blind ditch in the original tunnel to form a closed loop with the drainage system in the tunnel to ensure the smooth discharge of water in the lining of the transverse tunnel. Finally, caulking with waterproof glue, filling with cement slurry and smoothing it, which is consistent with the appearance of the lining.

For the construction joints with small water seepage, grouting plugging method is adopted to deal with them, so as to fill cracks, condense soil and cut off water sources. The specific construction technology is as follows: firstly, hole layout. According to the seepage area and position, the grouting hole is arranged at the seepage joint with an electric drill, the hole depth is half of the concrete thickness, and the grouting hole is cleaned with a cleaning machine.

Embed the grouting pipe, fix the grouting pipe with quick hardening waterproof mortar, and wipe the surface of the joint. Then grouting. Water-soluble polyurethane plugging agent is injected into the hole by intelligent high-pressure grouting pump through grouting nozzle. When the material meets water, it immediately generates a water-insoluble gelatinous substance and expands in the joint with 5 ~ 10 times the volume. Cleaning and appearance treatment. A few days after grouting, cut off the exposed part of grouting pipe, smooth the surface with waterproof mortar, and pay attention to adjusting the color of mortar to ensure the overall appearance quality of lining. In the treatment of water seepage in construction joints of several tunnels of Heda Expressway, a new type of environmental protection PTN joint adhesive is adopted. Compared with traditional joint adhesive, PTN joint adhesive has the advantages of low density, high bonding strength, good durability, wide base materials and environmental protection, and has achieved good results in the treatment of water seepage in Heda Expressway Tunnel.

5 Summarize

Based on the fluid structure coupling mechanism, the seepage mechanism of highway tunnels was deeply explored, and the mechanical properties of tunnels under seepage were analyzed through experimental data and numerical simulation. The water damage control of the Dabaoshan Tunnel mainly focuses on intercepting and draining surface water collected by atmospheric precipitation. The main technical measures are to use materials with poor permeability for backfilling and compaction, use concrete to seal and isolate water on the surface, and improve the drainage system on the surface. The research results indicate that the seepage field has a significant impact on the stress distribution and stability of tunnel lining. When the seepage pressure reaches a certain threshold, cracks appear in the tunnel lining, and the number and distribution of cracks are closely related to the seepage field. The numerical simulation further reveals the interaction mechanism between the seepage field and the tunnel structure, confirming the influence of the seepage field on the stability of the tunnel lining. When the seepage pressure increases to 4.0 MPa, the displacement change rate of the tunnel lining reaches 0.3 mm/m, and the maximum lining stress is 15.7 MPa. Further research on the seepage mechanism and mechanical properties of highway tunnels, while strengthening the monitoring and maintenance of tunnel engineering, timely detection and treatment of tunnel lining cracks, and ensuring the safe operation of the tunnel.

Acknowledgments

This study is supported by “R&D projects in key areas of Guangdong Province-NO.2022B0101070001”.

References

- [1] Zhenhua, W. (2018). Study on structure technology of high-cold and super-long tunnel under high stress and rich water environment. *Railway Construction Technology*.
- [2] Jiang, A., Yang, X., Xu, M., and Jiang, T. (2021). Coupled hydrologic-mechanical-damage analysis and its application to diversion tunnels of hydropower station. *Advances in Civil Engineering*.
- [3] Contescu, C., Strizak, J., Tyler, Guldan, and Burchell, T. (2020). Effect of air oxidation on pore structure development and mechanical properties of nuclear graphite.
- [4] Xuan, N., Jing, L. I., Yan-Hui, L., Fu-Chao, O. U., and Jing, W. (2019). Mechanical characteristics analysis of pumped concrete pipe breakage based on fluid-solid coupling. *Water Resources and Power*.
- [5] Kevin, A., Akbar, M., Gunawan, L., Aulia, D. K., Agung, R., Rawikara, S. S., Sasongko, R. A., and Widagdo, D. (2023). Evaluation of Piezoelectric-based Composite for Actuator Application via FEM with Thermal Analogy. *European Journal of Computational Mechanics*, 32(05), 495–518.
- [6] Smirnov, I.V., Ditenberg, I.A., Tyumentsev, A.N., Pinzhin, Y.P., Grinyaev, K.V., and Osipov, D.A., et al. (2023). Influence of thermal treatment mode on thermal stability of microstructure, mechanical properties, and fracture features of v-cr-w-zr alloy. *Physics of Atomic Nuclei*, 86 (Suppl 1), S75–S80.
- [7] Zhang, G., Wang, J., Liu, X., Li, M., Chen, C., and Wang, N., et al. (2023). Correlation between the micro-structure and macroscopic mechanical properties of gap-based propellant during aging. *Polymer Degradation and Stability*.
- [8] Youjun, J., Vafai, K., Xu, H., and Jianjun, L. (2020). Analysis of the channel of water injection in low permeability reservations with interlayer considering the seepage-stress coupling. *International Journal of Numerical Methods for Heat and Fluid Flow*, head-of-print (head-of-print).

- [9] Yunhong, G., and Liang, Z. (2023). Slope Stability Analysis Based on the Coupling of SA and Limit Equilibrium Mechanics. *European Journal of Computational Mechanics*, 32(02), 103–132.
- [10] Xu, G., Hao, M., and Jin, H. (2018). Study on Fluid-solid Coupling Mathematical Models and Numerical Simulation of Coal Containing Gas. *Iop Conference Series: Earth and Environmental Science* (Vol. 113). IOP Conference Series: Earth and Environmental Science.
- [11] Li, B., Yang, K., Xu, P., Xu, J., Yuan, M., and Zhang, M. (2018). An experimental study on permeability characteristics of coal with slippage and temperature effects. *Journal of Petroleum Science and Engineering*.
- [12] Huang, J., Wang, T., Lueth, T. C., Liang, J., and Yang, X. (2020). Cfd based on the hydroplaning mechanism of a cormorant's webbed foot propulsion. *IEEE Access*, PP(99), 1–1.
- [13] Wang, T., He, Y. M., Wu, Z., and Li, J. J. (2023). A study on impacts of groundwater seepage on artificial freezing process of gravel strata. *Railway Sciences*, 2(1), 1–12.
- [14] Dou, S., Hao, L., Wang, Q., Liu, H., and Yan, J. (2024). Effects of agglomerate structure and operating humidity on the catalyst layer performance of PEM fuel cells.
- [15] Yang, J., Li, H., Harvey, J., Yang, B., Mahmud, S., and Zhang, Y., et al. (2021). Investigation on mechanical properties and water stability of porous polyurethane concrete. *Transportation Safety and Environment*.
- [16] Qiao, Z. (2021). Research and experimental analysis of hydraulic cylinder position control mechanism based on pressure detection. *Machines*, 10.
- [17] Lin, J., Zhu, Y., Hou, J., Pan, B., and Huang, W. (2021). Equivalent continuum coupling-based slope stability analysis of zhouning pumped storage power station. *Geofluids*, 2021(9), 1–13.
- [18] Shan, Y., Xingfen, M., and Qizhi, H. U. (2018). Study on failure criterion of sandstone under water-rock coupling based on energy principle. *Mining Research and Development*.
- [19] Fu, B., and Wang, B. (2021). An influence study of face length effect on floor stability under water-rock coupling action. *Geofluids*.
- [20] Hu, Q., Tang, Y., and Ding, Z. (2020). Study on the stability of a transition section from soft to hard surrounding rock based on the solid-fluid coupling effect. *Advances in Civil Engineering*.
- [21] Yang, X., Xu, Z., Chai, J., Qin, Y., and Cao, J. (2023). Numerical investigation of the seepage mechanism and characteristics of soil-structure interface by cfd-dem coupling method. *Computers and geotechnics*.

- [22] Cui, S., Liu, P., Li, Z., Xu, X., and Ju, J. W. (2020). Shotcrete performance-loss due to seepage and temperature coupling in cold-region tunnels. *Construction and Building Materials*, 246, 118488.
- [23] Pengxiang, C. (2019). Mechanical calculation method of drainage channel with considering fluid-solid coupling. *Shaanxi Water Resources*.
- [24] Shen, R., Zhang, K., and Shi, J. (2022). Research on Hydraulic Power System Operation Status Diagnosis Technology Based on Hybrid CNN Model. *European Journal of Computational Mechanics*, 31(03), 387–408.
- [25] Cheng, P., and Man, W. (2019). The analysis on influence of geotextile on seepage-stress field of tailings dam based on fluid-structure interaction theory. *Journal of University of South China (Science and Technology)*.
- [26] Chuang, W. (2018). Disturbance Analysis of Shallow Buried and Small Interval Shield Tunnel Excavation Based on Fluid-solid Coupling.
- [27] Cong, L., Shucai, L., Zongqing, Z., Liping, L., Shaoshuai, S., and Yuxue, C. (2018). Numerical analysis of surrounding rock stability in super-large section tunnel based on hydro-mechanical coupling model. *Geotechnical and Geological Engineering*, 37.
- [28] Zhang, Z., Zhang, Q., Xiang, W., and Xue, T. (2021). Development and application of a three-dimensional geo-mechanical model test system under hydro-mechanical coupling. *Geotechnical and Geological Engineering*.
- [29] Qiu, P. T., Chen, Z. Q., Pu, H., and Zhu, J. (2019). Coupling effects of porosity and particle size on seepage properties of broken sandstone based on fractional flow equation. *Thermal Science*, 23, 182–182.
- [30] Liang-Zhen, L. I., Yan-Jun, Z., Sheng-Wu, Q., Hao, D., and Jin, N. I. (2019). Analysis of three-dimensional fluid-solid coupling stability in tailings slope based on midas. *Global Geology*.

Biographies



Li Qing received the master's degree in engineering from Chang'an University in 2006. He is currently working as an senior engineer at the Department of geotechnical engineering of Guangdong Transportation Technology Testing Co., Ltd. His research areas and directions include slope and tunnel safety monitoring, consulting evaluation and maintenance of reinforcement design.



Lu Hao received the doctor's degree in engineering from Chang'an University in 2018. He is currently working as an engineer at the Department of geotechnical engineering of Guangdong Transportation Technology Testing Co., Ltd. His research areas and directions include geotechnical engineering monitoring, consulting evaluation, disaster prevention and related scientific research.