

A USABILITY STUDY OF A MOBILE CONTENT SHARING SYSTEM

ALTON Y. K. CHUA, DION HOE-LIAN GOH, KHASFARIYATI RAZIKIN

Nanyang Technological University
{altonchua, ashlgoh, khasfariyati}@ntu.edu.sg

EE-PENG LIM

Singapore Management University
eplim@smu.edu.sg

Received January 6, 2011

Revised March 16, 2011

We investigate the usability of MobiTOP (Mobile Tagging of Objects and People), a mobile location-based content sharing system. MobiTOP allows users to annotate real world locations with both multimedia and textual content and concurrently, share the annotations among its users. In addition, MobiTOP provides additional functionality such as clustering of annotations and advanced search and filtering options. A usability evaluation of the system was conducted in the context of a travel companion for tourists. The results suggested the potential of the system in terms of functionality for mobile content sharing. Participants agreed that the features in MobiTOP were generally usable as a content sharing tool. Implications and future work are also reported in this paper.

Key words: Location-based annotation, mobile content sharing, usability evaluation, MobiTOP

1 Introduction

Over the last two decades, mobile phones have grown from being a luxury device to a ubiquitous, indispensable personal item. Equipped with global positioning systems (GPS) that track users' location and Internet connectivity (GPRS, 3G or Wi-Fi) that grants easy access to the Web, mobile phones have evolved from a mere communication tool into a useful platform for sharing location-based content. ZoneTag [12], for example, is a camera phone application that enables users to capture, annotate, and share photos directly from their phones, while MMM [22] allows users to annotate digital photos at the time of capture. Particularly in the travel and tourism industry, travellers now use their mobile phones not only to make phone calls and send text messages but also share personal experiences through content-sharing mobile applications. Micro-Blog [4] enables travellers to share their travel experience by creating micro-blogs on their phones in situ. The element of shared experiences is also seen in the work by Garcia et al [5], who introduce an application where travellers could snap a photograph and annotate it with tags using their phones.

In addition to images, other content types may also be shared. For example, using mobile phones, users may annotate a place of interest with descriptive textual comments, location information (latitude

and longitude), and multimedia (e.g. images or video). This information can then be uploaded and shared with other users. One such system is MobiTOP (Mobile Tagging of Objects and People), a mobile application that allows users to annotate real-world locations with multimedia content. Further, unlike existing content sharing systems, MobiTOP's annotations are organized hierarchically, allowing other users to annotate on existing annotations, in the spirit of many other social computing applications. This collaborative annotating process forms a threaded discussion on a topic, allowing a community of users to exchange and explore information [9]. In previous work [18, 13], MobiTOP was evaluated with the intention to solicit feedback about the application and to study information behavior while using the system. However, such work had shortcomings that warrant the current research. First, Razikin et al. [18] adopted a small-scale qualitative study whose results may not be generalisable to mobile content sharing systems in general. Next, Nguyen et al. [13] only compared the effectiveness of different interfaces for accessing hierarchically organized annotations, and not the full suite of MobiTOP's functionality.

As part of on-going work, the purpose of this paper is to investigate the overall usability of MobiTOP, as well as that of its functional components. This is done in the context of a travel companion for tourists. This study is not only significant in shaping the development of MobiTOP but also holds implications for both researchers and developers interested in location-based content-sharing mobile applications. Similar works [e.g. 4, 6] have evaluated mobile content sharing systems. However, the evaluation done in these works were not comprehensive. For instance, Gaonkar et al. [4] examined the effects of incentives, privacy and unreliable content in a small-scale study whose participants were likely to be early adopters of mobile technologies and services. Also, MoTag [6] was evaluated, as a whole, by a twelve volunteers using generalized heuristics, or usability principles, and did not focus on the individual components of the application. Hence, as seen from the increasing popularity of mobile content sharing systems, our study is both relevant and timely.

The remainder of this paper is organized as follows: Section 2 reviews work related to content-sharing mobile applications. Following that, Section 3 describes MobiTOP and its functionalities. Section 4 presents the methodology in this study, including the data collection procedures and instrument. The results obtained are highlighted in Section 5. Finally, Section 6 discusses the implications arising from results and concludes the paper.

2 Related Work

Location-based content-sharing applications represent an important emerging genre in the mobile software space. While many of them have yet to be commercialized, a number of research prototypes can be gleaned from the literature. MobShare [20] is a mobile phone picture sharing system that enables users to upload mobile images to an organized web album with full access control. It also supports the combination and comparison of personal and shared pictures. Similarly, ZoneTag [12] and MMM [22] allows users to capture photos from their camera phone, and upload the photos subsequently from the time of capture to either their server or a photo-sharing site like Flickr. However, users can only share either images or tags.

Place Mail [11] is a location-based reminder system with which users can create personal reminder data about various geographical locations (called message). Users would be alerted when they arrive within the vicinity of a location where a message had been previously stored. By viewing the message,

users can gain new insight about that location. Similarly, PALASS [15] is a location-aware framework for portable handheld devices based on Google Android platform. PALASS presents the concept of Place which is defined as an event associated with a geographical position at a specified time. However, information sharing in both Place Mail and PALASS is only limited to textual content. Moreover, the location-based content can only be accessed at the actual physical location.

As a traveller's guide, iCity [1] is an adaptive, social multi-device recommender guide that provides information about the cultural resources and events promoting the cultural heritage in the city of Torino. CoMPASS [2] is a complex geographical information system which offers full geospatial functionality through its client interface, such as navigation, querying, map personalization and annotation. Micro-Blog [4] allows users to generate and share geo-tagged multimedia called microblogs. The data can be browsed or queried through an Internet map service as users move through a location. Mobile G-portal [21,10] is a learning assistant which is integrated with a Web-based geospatial digital library of geography resources. It supports collaborative sharing and learning for geography fieldwork. Finally, MoTag [6] is a mobile application can help people with disabilities navigate around their environment by enabling them to share up-to-date accessibility information about buildings and other physical structure. Nonetheless, these systems generally do not support users' further effort to enrich the content with more information. Moreover, they lack advanced search functionality and information management facilities, necessary in the resource-constrained mobile devices. We have attempted to address these shortcomings in this present work.

3. Introducing MobiTOP

MobiTOP is a mobile application that supports a map-based visualization for exploring and sharing hierarchical geospatial annotations. MobiTOP is written using J2ME and has been tested on Nokia N95 8GB phones. Location is determined by GPS when users are outdoors or is indicated manually on the map by the users when they are indoors. Communication with the MobiTOP server is achieved through GPRS, 3G or Wi-Fi networks.

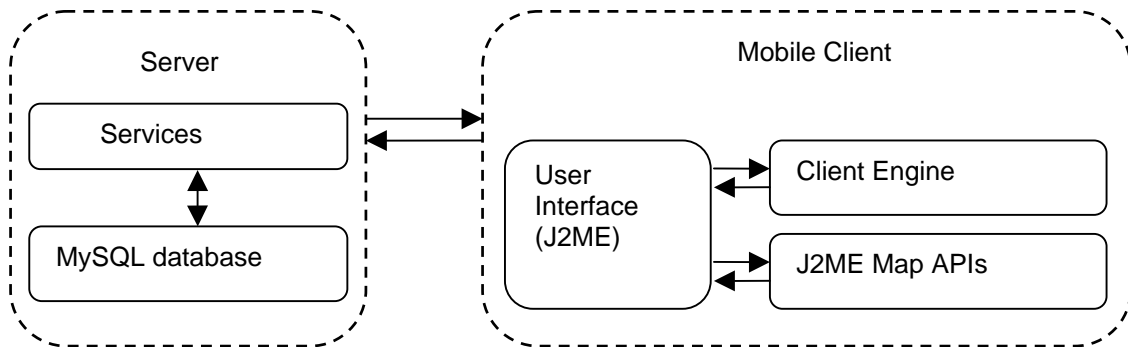

Figure 1. The architecture of the MobiTOP system.

3.1. Architecture

MobiTOP employs a client/server architecture (Figure 1) and consists of a single server and mobile client. MobiTOP's server makes use of LAMP (Linux, Apache, MySQL, PHP) open source software as the solution stack for its infrastructure. It runs on Linux with an Apache server and is implemented using PHP scripts and a MySQL database. MobiTOP's architecture is adopted from G-Portal [10] and retains some of G-Portal's backend design. For instance, the user database stores the user's profile such as their username and password. Also, the annotation database stores the annotations with the geo-referenced locations and attached media. The server communicates with its clients using XML over HTTP.

3.2. Annotations

In MobiTOP, annotations consist of locations, multimedia and textual information (titles, tags and descriptions). Due to the small display screen of the mobile phones, annotation content is presented in a tabbed format to accommodate different types of information. Figure 2 shows an example of an annotation. The contents of the annotation are displayed in three tabs. In each tab, information is arranged as follows:

- a. **Detail:** Contains textual information about the annotation such as title, creator, date when it was last edited, ratings given, description and tags assigned to the annotation (Figure 2a).
- b. **Tag Cloud:** Shows visualization of all the tags that are assigned to the current annotation and its sub-annotations (Figure 2b). The size of the individual tags is related to the number of times the tags are used.
- c. **Media:** Shows all the images related to the annotation (Figure 2c). A user can browse as well as view the image in full screen size.



(a)



(b)



(c)

Figure 2. Details of an annotation

3.3. Functionality

MobiTOP's functionality is divided into eight main components:

- a. **Registration:** Before contributing and exploring annotations in MobiTOP, a user needs to register an account. Access to the main interface is granted once a user has been authenticated.
- b. **Accessing annotations:** Users are able to access annotations through three different ways, namely a map, list or hierarchical tree. The map-based visualization (Figure 3) presents the annotations in the form of markers. Annotations are also organized in a list that shows each individual annotation title, description and a thumbnail of one its photos where available. The tree visualization allows access to hierarchically organized annotations via a tree-like navigational interface [9]. The root annotation is located at top of the tree and its sub-annotations follows at different levels under the root annotation (Figure 4). Finally, MobiTOP keeps users updated with a quick view function that lists recently created annotations by all MobiTOP's users.



Figure 3. Annotations on a map-based visualization

- c. **Map navigation:** MobiTOP provides standard features for map navigation such as zooming and panning. Users are also able to reposition the map's current view to another location by entering the desired address.
- d. **Creating annotations:** Users can create annotations by harnessing the GPS function when they are outdoors or manually indicating their position on the map when they are indoors. After the location is specified, information such as those in Figure 2 can be entered. Images for the annotation may be captured using MobiTOP's built-in camera function.
- e. **Editing/deleting annotations:** Users can edit or delete the annotations that they had previously created.



Figure 4. Hierarchical structures of annotations in tree visualization

- f. **Searching annotations:** Users are able to search for desired annotations with relevant keywords. They are also given the options to limit the search results by the area (i.e. everywhere or area of the map) and time. At the same time, they are given the option to view the search results in clusters. When user performs a search without viewing the results in clusters, the system will return all the annotations that match the keywords (Figure 5).

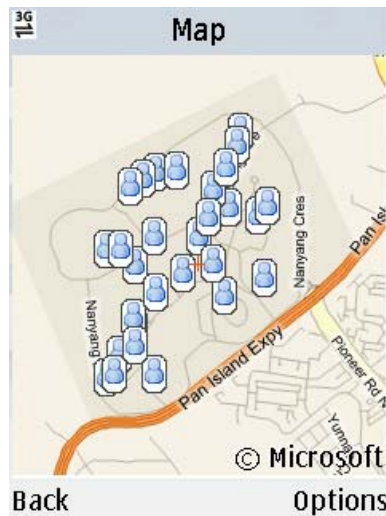

Figure 5. Search results visualized on a map

- g. **Searching annotation with clusters:** Users are able to view the search results in clusters. The main motivation for clustering the search results is because the retrieved annotations could clutter the map and impede the searching process when too many annotations are returned [7]. When the option to cluster the search results is selected, the returned annotations are grouped based on their locations. The clustering algorithm is an adaptation of DBScan [3] that groups the annotations by the number of annotations in the area [17]. The novelty of this approach is that clustering is performed dynamically depending on the zoom levels and the actual distance among the annotations. Figure 6 shows an example of the search results with clustering. When users perform a search with the clustering option, all annotations which that match the search term will be returned. Where clustering is specified, MobiTOP groups all the geographically proximal annotations into clusters and presents them with a different marker from regular annotations.



Figure 6. Clustered search results.

- h. **Filtering annotations:** MobiTOP allow users to filter the annotations based on predefined conditions. Users can choose to view the annotations from a particular creator or annotations created within a time period.

4. Methodology

Data in this study was collected from 127 participants via eight evaluation sessions. Lasting approximately 1.5 hours, each session involved 15-20 participants and was divided into two segments. In the first segment, participants, recruited from an invitation email within a local university, were briefed on the concept of annotations and were introduced to MobiTOP. A set of eleven scenario-based tasks was then assigned to the participants for evaluation. The tasks focused on using the seven components of MobiTOP as described in Section 3. For example, participants were required to use

MobiTOP to seek information, share comments about various places as well as create their own annotations. Where needed, research assistants were on hand to help participants with the tasks.

In the second segment the session, participants completed a questionnaire which was structured into two sections, namely, demographic and usability. The demographic section was intended to capture participants' details such as gender, age, academic background and familiarity with social computing applications. To measure MobiTOP's usability, we adopted four main usability indicators from previous work [14,23,16]:

- Learnability: measures how easily users learn to navigate the system and complete a task [19].
- Efficiency: determines users' ability to complete a task within a reasonable amount of time [23].
- Error Handling: verifies users' understanding of errors encountered and the ability to recover from the errors [16].
- Satisfaction: validates users' sense of satisfaction after completing the tasks and intention to adopt the system [23].

A total of 33 items in the usability section of the questionnaire were given in the form of affirmative statements and accompanying responses in a Likert-scale (1 = strongly disagree; 5 = strongly agree). The items covered both MobiTOP's usability in general, as well as the usability of each of the seven components in MobiTOP (see Section 3). Participants were also encouraged to elaborate on their evaluations by answering three open-ended questions about which components they liked, which components they disliked, and suggestions of useful features that could be included in future versions of MobiTOP.

5. Results

Of the 127 participants who took part in this study, 79 were male while 48 were female. Their ages range between 18 and 32 (mean = 23). Although participants were students of a local university, many of them were working adults who were enrolled in part-time degree programs. The majority had an Engineering (40.94%) background. The rest were from backgrounds including Computer Science (27.56%), Economics (5.51%), Biological Sciences (5.51%), Business and Finance (3.94%), Chemistry (2.36%), Physics (2.36%), Education (1.57%), Design (0.79%), Communications (0.79%) and other majors (3.15%).

Participants were familiar with the use of social computing applications such as blogs, wikis, photo/video sharing, social tagging and social networking. Some 84% of the participants viewed such content on the web at least once a week, while 77% contributed such content on the web at least once a month. On the other hand, they seemed less familiar with such applications on mobile phones. Only 48% reportedly viewed such content on mobile phones only once a month, while 34% contributed to such content on mobile phones at least once a month.

Table 1 shows the mean and standard deviations (S.D.) of MobiTOP's usability with respect to the four indicators: learnability, efficiency, error handling and satisfaction. The results suggested that the participants found MobiTOP to be relatively usable, with scores above three. It was observed during the evaluation sessions that participants were quick to adapt themselves to the mobile application, suggesting learnability (*“easy to use even at the very beginning”* – Participant 61, *“easy to learn”* –

Participant 89). In addition to learnability, participants were observed to complete the tasks with ease during the evaluation session. This corroborated the efficiency indicator score. Further, most participants were able to understand the error messages when using MobiTOP and could rectify errors without any difficulties. Finally, participants expressed enjoyment in sharing information through the annotations and were satisfied with the application. Participant 76 shared that MobiTOP “*helps me in getting to the right places and (it is) convenient. I can communicate and maintain relationships with new friends and old friends by sharing photos and places*”, while Participant 111 highlighted that he could “*easily organize events and share it on MobiTOP*”.

Table 1. Overall usability results (1 = strongly disagree; 5 = strongly agree).

Usability Indicators	Mean	S.D.
Learnability	4.00	0.49
Efficiency	3.65	0.64
Error Handling	3.47	0.72
Satisfaction	3.75	0.66

In addition to the overall usability, Table 2 shows the means and standard deviations for the usability of the seven main components of MobiTOP. The results show that the individual components are also generally usable from the perspective of the participants.

Table 2. Components' usability results (1 = strongly disagree; 5 = strongly agree).

Components Usability	Mean	S.D.
Registration	4.20	0.56
Accessing Annotations	4.22	0.65
Map Navigation	3.91	0.69
Creating Annotations	4.10	0.63
Editing/Deleting Annotations	3.83	0.67
Searching Annotations	3.93	0.60
Filtering Annotations	3.86	0.54

- a. **Registration:** All the participants were able to create their accounts to log into the system. They found the registration form easy to understand. For example, Participant 91 stated that “*it was easy to create my user account*”. Participant 63 noted that the registration process was “*simple and straightforward (and there is) no need to fill in excessive information*”. Participant 110 also shared that he felt that his privacy was not intruded as MobiTOP does not require “*unnecessary information*” to register. Any errors that occurred during the registration process (e.g. missing required fields, entering duplicate usernames) were easily recovered without needing extra help. Only Participant 36 found the registration process to be “*not so*

convenient”, possible due to the need to enter textual information using the numeric keypad of the mobile phone.

- b. **Accessing annotations:** Participants found that it was easy to access the annotations. The reason could be because MobiTOP provides multiple points of access to the annotations. Participant 11 highlighted that list and hierarchical tree visualizations gave *“more details (making annotations) comprehensive”*. Similarly, Participant 122 showed interest in the quick view as it *“helps me check if my recent annotations (that had been) created are saved, (this) ensures that I did not miss anything”*. Additionally, the annotations’ hierarchical structure visualized were reported to be *“clear and informative”* by Participant 97. However, the quantity of annotations displayed on the map created difficulty in browsing. Here for example, Participant 54 disliked *“viewing annotation on the map (because) too many icons (are) displayed”*.
- c. **Map navigation:** The majority of the participants (93%) agreed that the map was easy to navigate. This could be due to their familiarity in seeking information through mapping applications such as Google Maps. Additionally, with the representation of the annotations on the map and the fast response times when browsing, the map visually helped participants in looking for their information, Participant 81 commented *“zoom in and out is responsive and fast”* and Participant 122 liked the fact that *“the locations of the places can be known from the map, saving time looking for places”*. Participant 83 also suggested that it was easy to search using the map view. However, there were comments regarding difficulty when using the map such as *“difficult to view the map in small mobile phone screen”* (Participant 54) or *“the map is too simple and it is difficult to find the exact location”* (Participant 62).
- d. **Creating annotations:** Most of the participants expressed interest in creating annotations because they were able to share their experiences. With the support of GPS and the ability to attach multimedia content, they were more than satisfied with the features associated with annotation creation, as it added an element of excitement to the participants’ annotations. Participant 3 noted that *“I am able to create an annotation at my desired location”* while Participant 27 added that *“attaching photo/media enables us to share experience, making it more lively”*. In addition, participants liked the idea of hierarchical annotation as they were able to comment on existing annotations. Participant 80 remarked that the sub-annotations *“allow me to comment or add in my thoughts to what I come cross”* while Participant 71 enthused that *“it’s a brilliant way to complement the previous comment!”* Annotations not only enrich the quality of content, but the hierarchical aspect also addresses the issue of duplicating annotation as Participant 85 noted *“(By) creating sub-annotation, there is no need to create another annotation for the same place”*. However, there were comments regarding efficiency when creating sub-annotation. Participant 27 remarked that *“I think it is not efficient to create a comment on annotation by using sub-annotation. It takes quite long time to create a sub-annotation”*. Similarly, Participant 80 commented, *“The sub-annotation requires me to key in too much information and can be confusing”*.
- e. **Editing/deleting annotations:** Participants agreed that the process of editing an existing annotation or deleting an annotation is easy. They also found that editing/deleting is useful as it is helpful for updating information as Participant 37 expressed *“With edit(ing) annotation(,)”*

I can change my mind and edit my previous annotations". Efficiency in editing and deleting annotations was also favored by the participants (*"Editing annotations is (done) quickly and easily"* – Participant 120). In contrast, other participants found it was tedious to edit the annotations as *"it took time"* (Participant 95).

- f. **Searching annotations:** All the participants were able to perform the search tasks. They also found that searching was easy to perform, and useful, as the results could be shown in a list and on the map. As Participant 1 put it: *"(The) map can be easily searched and I can see the places I want to go. The list view (enables us to) see the list of annotations that we search"*. Further, the search with clustering feature was well received by the participants. Participant 34 commented, *"The search results are clearer and more convenient to access for users because related annotations are grouped"*. Participant 65 summed this succinctly: *"Cluster search is helpful (as) the system is able to return desired search results in an easy to understand form"*. However, there were suggestions that searching within the search results should be supported. Participant 55 shared, *"it is very hard to find annotation if there are many results that match the first search"*. The clustering technique also raised concerns about browsing clustered results as *"you have to search and browse the list one item at a time to find the desired threads"* (Participant 18).
- g. **Filtering annotations:** This feature was useful as it had many options for participants to filter the annotations. Participant 123 found that filter by user helped him *"get information from your friend quickly"*, while Participant 33 saw the usefulness of the time filter as it *"show(ed) only events taking place during my short trip"*. Other participants found that the time filter did not help them find information as they found entering the search parameters to be not intuitive (Participant 23).

6. Discussion and Conclusion

In this paper, we conducted a usability evaluation of MobiTOP, a location-based mobile annotation system. The application allows users to create, browse and share hierarchical location-based annotations. As shown in our results, the average overall usability solicited from 127 participants was found to lie above the mid-point on the 5-point Likert-scale. Despite the fact that all of participants were new to MobiTOP and many of them were new to concepts such as hierarchical annotations and clustering of search results, they found these ideas easily understandable and they were able to apply them in completing the given tasks.

Three main findings emerge from our investigation. First, our results indicated that the participants had positive sentiments towards the concept of location-based annotations as well as the hierarchical aspect of organizing annotations in MobiTOP. The media rich annotations enabled the participants to view information that was related to a location, enabling them to *"understand more (about) the place"* (Participant 75). At the same time, the annotations provided a platform for communication between the users and this in turn has the potential to forge new relationships or maintain existing ones between users. Finally, the different access mechanisms in MobiTOP allowed the participants the freedom to access content in their most preferred way.

Second, participants were also positive about the search functionality with clustering and filtering options. Perhaps this was because they were able to view the search results in either a list or on the map. Further, clustering helped the participants to concentrate their search to a specific area, hence making the “*search more efficient*” (Participant 33). This is notable as our work suggests that clustering is a viable option to manage search results listings on a small screen device. The standard approach of listing pages of results, or plotting individual results on a map clutters the screen, making it difficult for users to sift through relevant content.

Finally, our study also illustrated that the limitation of the mobile phone for creating and searching annotations remained a challenge for sustained usage. Textual input was one possible issue here as the mobile phone’s numeric keypad limited the users’ ability to enter large amounts of text (“*cumbersome input*” – Participant 12). The slow network speed when compared to wired network connections was also a problem as it affected the usability of MobiTOP. In particular, participants were not satisfied with the response times for executing searches and accessing annotations.

On the basis of our findings, the following are some implications for designing future versions of MobiTOP and location-based mobile annotation systems in general:

- As annotations contain multimedia, textual and location-based information, multiple views of annotations should be supported to improve access to content. In MobiTOP, both the list and map visualization helps users in browsing for annotations if users have some general idea about the desired content but do not know the specific keyword or location. Here, the list gives users an overview of the textual information while the map helps users view annotations at a particular location. Further, the tree-like navigational interface eases access to the hierarchical information in annotations.
- As searching is an integral feature in any information system, an effective way to browse search results will expedite access to desired information. Presenting the annotations on the map may overwhelm the user especially when there are large numbers of annotations returned in a search. In our work, we found that clustering proximate annotations into groups helped alleviate the problem of information overload.
- Creating annotations require users to input textual information. One of the ways to facilitate this process is to provide users with recommendation mechanisms so that users need only to select from a list of suggested text using navigation keys instead of entering text using the keypad. Also, users should be given the flexibility to create and upload annotations either *in situ* or defer to a later time since some locations may suffer from poor network coverage or GPS signals.

Our study serves as springboard for at least three future research directions. First, this study investigated on the usability of the system. However, the success of a system is also dependent on its continued usage by the users of the system as seen from a previous study by Theng et al [21] Thus, future studies could seek to understand users’ motivation for continued usage of MobiTOP [8]. Next, the use of MobiTOP in other domains could be explored. Since prior studies have focused in education domain and in this study we concentrated in tourism domain, it would be worthwhile to look into the use of MobiTOP in other domains. For instance, the application could be used by people with special needs to help them with their daily activities [e.g. 6]. Finally, our system did not include any means to

reduce the need to keying in textual information. Here, a potential area of improvement is the integration of recommendation algorithms [12, 24].

Acknowledgements

This work was by partially funded by A*STAR grant 062 130 0057.

References

1. Carmagnola, F., Cena, F., Console, L., Cortassa, O., Gena, C., Goy, A., Torre, I., Toso, A. and Venero, F. (2008) Tag-based user modeling for social multi-device adaptive guides. *User Model and User Adapted Interaction*, 18(5), 497-538.
2. Doyle, J., Bertolotto, M., and Wilson, D. (2010). Evaluating the benefits of multimodal interface design for CoMPASS-a mobile GIS. *Journal of GeoInformatica*, 14(2), 135-162.
3. Ester, M., Kriegel, H. P., Sander, J. and Xu, X. (1996). A density-based algorithm for discovering clusters in large spatial databases with noise. In *Proceedings of the 2nd International Conference on Knowledge Discovery and Data Mining* (pp. 226-231) AAAI Press: California.
4. Gaonkar, S., Li, J., Choudhury, R.R., Cox, L. and Schmidt, A. (2008). Micro-blog: sharing and querying content through mobile phones and social participation. In *Proceeding of the 6th International Conference on Mobile Systems, Applications and Services* (pp. 174-186). ACM Press: New York.
5. Garcia, A., Linaza, M. T., Arbulu, I., Torre, I. and Cobos, Y. (2008). A mobile platform for on-the-move user-generated tourist contents. In *Proceedings of the International Workshop on Content-Based Multimedia Indexing* (pp. 58-65). IEEE: California.
6. Goh, D. H. -L., Sepoetro, L. L., Qi, M., Ramakhrisnan, R., Theng, Y. L., Puspitasari, F. and Lim E. P. (2007). Mobile tagging and accessibility information sharing using a geospatial digital library. In *Proceedings of the 10th International Conference on Asian Digital Libraries* (pp. 287-296). Springer: Berlin.
7. Jaffe, A., Naaman, M., Tassa, T. and Davis, M. (2006). Generating summaries and visualization for large collections of geo-referenced photographs. In *Proceedings of the Multimedia Information Retrieval* (pp. 89-98). ACM Press: New York.
8. Kaasinen, E. (2003). User needs for location-aware mobile services. *Personal Ubiquitous Computing*, 7(1), 70-79.
9. Kim, T. N. Q., Razikin, K., Goh, D. H. -L., Theng, Y. L., Nguyen, Q. M., Lim, E. P., Sun, A., Chang, C. H. and Chatterjea, K. (2009). Exploring hierarchically organized georeferenced multimedia annotations in the MobiTOP system. In: *Proceedings of the 6th International Conference on Information Technology: New Generations* (pp.1355-1360). IEEE: California.
10. Liu, Z. H., Yu, H., Lim, E. P., Yin, M., Goh, D. H. -L., Theng, Y. L., and Ng W. K. (2004). A java-based digital library portal for geography education. *Science of Computer Programming*, 53(1), 87-105.
11. Ludford, P. J., Priedhorsky, R., Reily, K., and Terveen, L. (2007). Capturing, sharing, and using local place information. In *Proceedings of the SIGCHI conference on Human Factors in computing systems* (pp. 1235-1244). ACM Press: New York.
12. Naaman, M. and Nair, R. (2008). Zonetag's collaborative tag suggestions: What is this person doing in my phone? *IEEE Multimedia*, 15(3), 34-40.
13. Nguyen, Q. M., Kim, T. N. Q., Goh, D. H.-L., Lim, E. P., Theng, Y. L., Chatterjea, K., Chang, C. H., Sun, A. and Razikin, K. (2009). Sharing hierarchical mobile multimedia content using the MobiTOP system. In *Proceedings of the 10th International Conference on Mobile Data Management: Systems, Services and Middleware* (pp. 637-642). IEEE: California.
14. Nielsen, J. (1993). Usability engineering. Morgan Kaufmann, San Diego.

15. Press, M., Goodwin, D., and Flores, R. A. (2008). PALASS: a portable application for a location-aware social system. In *Proceedings of the On the Move Workshop: On the Move to Meaningful Internet Systems* (pp. 499-508). Springer: Berlin.
 16. Quach, H.N.H., Razikin, K., Goh, D. H.-L., Kim, T. N. Q., Pham, T. P., Theng, Y. L., Lim, E.-P., Chang, C. H., Chatterjea, K. and Sun., A. (2010). Investigating perceptions of a location-based annotation system. In *Proceedings of the 6th International Conference on Active Media Technology* (pp. 232-242). Springer: Berlin.
 17. Razikin, K., Goh, D. H.-L., Lim, E. P., Sun, A. ., Theng, Y. L., Kim, T. N. Q., Chatterjea, K. and Chang, C. H. (2010). Managing media rich geo-spatial annotations for a map-based mobile application using clustering. In *Proceedings of the 7th International Conference on Information Technology: New Generations*, IEEE, California, 138-143.
 18. Razikin, K., Goh, D. H. -L., Theng, Y. L., Nguyen, Q. M., Kim, T. N. Q., Lim, E. P., Chang, C. H., Chatterjea, K. and Sun, A. (2009). Sharing mobile multimedia annotations to support inquiry-based learning using MobiTOP. In *Proceedings of the 5th International Conference on Active Media Technology* (pp. 171-182). Springer: Berlin.
 19. Ryan, C. and Gonsavles, A. (2005). The effect of context and application type on mobile usability: An empirical study. In *Proceedings of the 28th Australasian Conference on Computer Science* (pp. 115-124). Australian Computer Society, Inc. Darlinghurst.
 20. Sarvas, R., Viikari, M., Pesonen, J. and Nevanlinna, H. (2004). MobShare: Controlled and immediate sharing of mobile images. In *Proceedings of the 12th Annual ACM international Conference on Multimedia* (pp. 724-731). ACM Press: New York.
 21. Theng, Y.L., Tan, K.L., Lim, E.P., Zhang, J., Goh, D.H.L., Vo, M. C. (2007). Mobile G-Portal supporting collaborative sharing and learning in geography fieldwork: An empirical study. In *Proceedings of the 7th ACM/IEEE-CS joint conference on Digital Library* (pp. 462-471). ACM Press: New York.
 22. Wilhelm, A., Takhteyev, Y., Sarvas, R., Van House, N., and Davis, M. (2004). Photo annotation on a camera phone. In: *Extended Abstracts on Human Factors in Computing Systems* (pp. 1403-1406). ACM Press: New York.
 23. Zhang, D. and Adipat B. (2005). Challenges, methodologies, and issues in the usability testing of mobile applications. *International Journal of Computer-Human Interaction*, 18(3), 293-308.
 24. Zhang, N., Zhang, Y., and Tang, J. (2009). A tag recommendation system for folksonomy. In *Proceeding of the 2nd ACM Workshop on Social Web Search and Mining* (pp. 9-16). ACM Press: New York.
- Beck, K. Extreme Programming Explained. Addison-Wesley, 1999.